



POSITION IT™

POSITIONIT POSITIONERS OPERATOR'S MANUAL



MM233TX2TXRX2



HM211TXXDXRX2



HM211TX2DXRX2

The Will-Burt Company
401 Collins Blvd
Orrville, OH 44667

www.willburt.com

PM-01011-A, October 2023
© 2023 The Will-Burt Company

Warranty

Will-Burt warrants its PositionIt™ to be free from defects in material and workmanship for a period of two (2) years, with such time period running from the date of shipment by Will-Burt. Will-Burt shall not be responsible for any damage resulting to or caused by its products by reason of failure to properly install, maintain or store the product; use of the product in a manner inconsistent with its design; unauthorized service, alteration of products, neglect, abuse, accident, or acts of God. This warranty does not extend to any component parts not manufactured by Will-Burt; provided, however, Will-Burt's warranty herein shall not limit any warranties by manufacturers of component parts which extend to the buyer.

THE FOREGOING WARRANTY IS IN LIEU OF ALL OTHER WARRANTIES, AND NO REPRESENTATIONS, GUARANTEES OR WARRANTIES, EXPRESS OR IMPLIED, INCLUDING BUT NOT LIMITED TO, A WARRANTY OF MERCHANTABILITY, FITNESS FOR A PARTICULAR PURPOSE, OR NON-INFRINGEMENT ARE MADE BY WILL-BURT IN CONNECTION WITH THE MANUFACTURE OR SALE OF ITS PRODUCTS. NO EMPLOYEE, DISTRIBUTOR, OR REPRESENTATIVE IS AUTHORIZED TO CHANGE THIS WARRANTY IN ANY WAY OR GRANT ANY OTHER WARRANTY ON BEHALF OF WILL-BURT.

Claims for defects in material and workmanship shall be made in writing to Will-Burt within thirty (30) days of the discovery of defect. Failure to provide notice as required hereby shall be conclusive evidence that the product was in conformity with the warranty, and Will-Burt shall be released from any and all liability relating to the product. Will-Burt may either send a service representative or have the product returned to its factory at Buyer's expense for inspection. If judged by Will-Burt to be defective in material or workmanship, the product will be replaced or repaired at the option of Will-Burt, free from all charges except authorized transportation.

THE REMEDIES OF BUYER SET FORTH HEREIN ARE EXCLUSIVE AND ARE IN LIEU OF ALL OTHER REMEDIES. THE LIABILITY OF WILL-BURT WHETHER IN CONTRACT, TORT, UNDER ANY WARRANTY, OR OTHERWISE, SHALL NOT EXTEND BEYOND ITS OBLIGATION TO REPAIR OR REPLACE, AT ITS OPTION, ANY PRODUCT OR PART FOUND BY WILL-BURT TO BE DEFECTIVE IN MATERIAL OR WORKMANSHIP. WILL-BURT SHALL NOT BE LIABLE FOR COST OF INSTALLATION AND/OR REMOVAL, OR BE RESPONSIBLE FOR DIRECT, INDIRECT, SPECIAL OR CONSEQUENTIAL DAMAGES OF ANY NATURE.

Document History

Document Numbers	Dates	Remarks
PM-01011	Oct 16, 2023	Initial Release.

Table of Contents

Section 1 Introduction	1-1
1.1 Safety Precautions	1-1
1.2 How this Manual is Organized	1-1
1.3 Additional Documentation	1-2
1.4 Definitions of Terms and Symbols	1-2
1.5 Specifications	1-4
1.6 Major Components	1-5
1.6.1 Positioner	1-5
1.6.2 Controller	1-6
1.6.3 Power/Data Cable	1-7
1.6.4 Positioner Power Supply	1-8
1.6.5 Barrel Connector (2.1 mm)	1-8
1.7 Quick Overview	1-9
Section 2 Installation	2-1
2.1 Pre-Installation Check	2-1
2.2 Installation Tools	2-2
2.3 Components	2-2
2.4 Unpacking	2-2
2.5 Mounting the Positioner	2-3
2.6 Wiring the System	2-4
2.6.1 Positioner Plugs	2-4
2.6.2 Connecting Power and Controls	2-8
2.7 Mounting the Payload	2-12
2.8 Setting Presets and Electronic Limit Stops	2-14
Section 3 Operation	3-1
3.1 Pre-Operation Check	3-1
3.2 Operation Tools	3-2
3.3 General Controls	3-2
3.3.1 GUI Installation	3-3
3.3.2 GUI Setup Instructions	3-3
3.3.2.1 Easysync Setup	3-3
3.3.2.2 WB Positioner Setup	3-3
3.3.2.3 Presets and Stow & Unstow Setup	3-4
3.3.3 PCB Reprogramming Instructions	3-5
3.3.3.1 RS232 Connection & Setup	3-5
3.3.3.2 Program Instructions	3-6
3.3.4 Keyboard	3-6
3.3.5 Joystick	3-7
3.3.6 Menu Functions	3-8
3.3.7 Presets	3-9
3.3.7.1 Setting Presets with the Keyboard	3-9
3.3.7.2 Recalling Presets with the Keyboard	3-9
3.3.8 Electronic Limit Stops	3-10
3.3.8.1 Adjust Limit Stops with the Keyboard	3-10
3.3.8.2 Restore Limit Stops with the Keyboard	3-11
3.4 Unstowing the Positioner	3-11

3.5 Stowing the Positioner	3-12
3.6 Transportation	3-12
Section 4 Maintenance	4-1
4.1 Routine Maintenance	4-1
4.2 Replacement Parts.....	4-1
Section 5 Troubleshooting	5-1
5.1 Troubleshooting Guide.....	5-1
5.2 Restoring Factory Defaults.....	5-3
5.2.1 CamID	5-3
5.2.2 MonID.....	5-3
5.2.3 Protocol.....	5-4
5.2.4 Baud Rate	5-5
Section 6 Appendix.....	6-1
6.1 Rackmount Controller (optional)	6-1
6.2 Supported Pelco D Commands.....	6-2
Section 7 Drawings.....	7-1

Table of Figures

Figure 1-1 Home Position (PI-150 Shown)	1-2
Figure 1-2 Positioner Directions (PI-150 Shown).....	1-3
Figure 1-3 Positioners	1-5
Figure 1-4 Default Joystick Controller.....	1-6
Figure 1-5 Power/Data Cable.....	1-7
Figure 1-6 Positioner Power Supply	1-8
Figure 1-7 Barrel Connector.....	1-8
Figure 2-1 Rear of Positioner (PI-150 Shown).....	2-3
Figure 2-2 Positioner Mounting Hole Pattern.....	2-3
Figure 2-3 Positioner Plug Locations (PI-150 Shown).....	2-4
Figure 2-4 Carefully Pull Out the Removable Plug, Gasket, and Attached Wires	2-5
Figure 2-5 Quick Connect	2-5
Figure 2-6 Remove the (4) Bolts Securing the Plug Plate	2-6
Figure 2-7 Remove Plug Plate and Gasket	2-6
Figure 2-8 Pull the Wires out the Bottom of the Positioner.....	2-7
Figure 2-9 Secure the Gasket and Removable Plug to the Bottom Egress	2-7
Figure 2-10 Secure the Plug Plate and Gasket to the Side Egress.....	2-8
Figure 2-11 Powered with 12 VDC	2-9
Figure 2-12 Powered with 24 VDC	2-10
Figure 2-13 Powered with VAC.....	2-11
Figure 2-14 PI-35 Payload Mounting Hole Pattern	2-12
Figure 2-156 PI-150 Payload Mounting Hole Pattern	2-13
Figure 3-1 GUI Layout.....	3-3
Figure 5-1 Start Up Screen	5-3
Figure 5-2 Menu Screen	5-4
Figure 5-3 Protocol Setup Screen.....	5-4
Figure 5-4 Dome Screen.....	5-4
Figure 5-5 Keyboard Setup Screen	5-5

Table of Tables

Table 1-1 Positioner Specifications.....	1-4
Table 1-2 Default Joystick Controller (P/N: 5098901) Specifications.....	1-4
Table 1-3 Standard Cables.....	1-7
Table 2-1 Tools and Materials Recommended for Installation.....	2-2
Table 3-1 Tools and Materials Recommended for Operation.....	3-2
Table 3-2 Limit Stop Adjustment Numbers.....	3-10
Table 3-3 Default Limit Stop Numbers.....	3-11
Table 5-1 Troubleshooting the Positioner.....	5-1
Table 5-2 Troubleshooting the Controller.....	5-2
Table 5-3 Resetting the Protocol.....	5-4
Table 5-4 Resetting the Baud Rate.....	5-5

(This page is intentionally left blank.)

Safety Summary

This section describes safety information for the PositionIt and its default joystick controller. These are recommended precautions that personnel must understand and apply throughout installation, operation, maintenance, and troubleshooting. Be sure to read and understand the entire manual before performing any procedure outlined in this manual.

SIGNAL WORD DEFINITIONS

WARNING

Warnings highlight an essential operating or maintenance procedure, practice, condition, statement, etc., which, if not strictly observed, could result in injury to, or death of, personnel or long-term health hazards.

CAUTION

Cautions highlight an essential operating or maintenance procedure, practice, condition, statement, etc., which, if not strictly observed, could result in damage to, or destruction of, equipment or loss of mission effectiveness.

Note: Notes highlight an essential operating or maintenance procedure, condition, or statement.

GENERAL SAFETY INSTRUCTIONS

The following are general safety precautions that are not related to any specific procedures. These are recommended precautions that personnel must understand and apply throughout installation, operation, maintenance, and troubleshooting. Additional precautions which apply to specific procedures and steps may be listed with the procedure or step to which they apply.

WARNING

Electrocution Hazard! Do not touch live wires. Make sure all power has been disconnected prior to performing installation or maintenance. Make certain that the area is free of overhead power lines and other unwanted sources of electricity. Do not operate the system during an electrical storm. Follow local safety regulations when working near energized power lines. Be sure to allow sufficient clearance on all sides of the mast to allow for side sway. Death or serious injury could result if proper precautions are not performed.

WARNING

Resuscitation! Personnel working with or near high voltages should be familiar with modern methods of resuscitation.

WARNING

Pinch Point Hazard! Keep clear of moving parts. Be sure to stay clear of the positioner during operation. Moving parts can crush and cut resulting in serious injury.

WARNING

Crush Hazard! Do not stand directly beneath the positioner or payload. Be certain payload is properly installed and secured. In locations or areas where the risk of injury occurs, or any part of the assembly may become detached or fall for any reason, a strong safety chain or wire hawser should be attached between the equipment and the mounting surface. At all times, normal safety precautions must be employed. Death or serious injury could result if positioner fails suddenly.

⚠ WARNING

Safety Equipment! Helmets or hard hats, eye protection, gloves, and safety shoes or combat boots must be properly worn while working in the deployment area. Death or serious injury could result if proper safety equipment is not properly worn.

⚠ WARNING

Trained Personnel Only! Installation, operation, and maintenance to be performed by trained and authorized personnel only. Death or serious injury could result if proper installation, inspection, operation, and maintenance procedures are not observed.

⚠ WARNING

Lifting Hazard! Manually lifting over 55 lb. (25kg) is prohibited. All lifting equipment must be thoroughly examined annually by a competent person.

⚠ WARNING

Safety Instruction – Remote Control! The equipment is subject to remote control and may be operated at any time. Persons working on the equipment should take appropriate precautions to ensure that any unexpected movement does not occur as this could lead to injury.

⚠ CAUTION

Equipment Damage! All persons installing and maintaining this equipment should be suitably qualified and work to national and local standards and codes of practice.

⚠ CAUTION

Equipment Damage! Each positioner contains a 1.85 amp self-resetting circuit breaker to protect the PC board. Do not disassemble the positioner side plates, or separate from the pedestal. Doing so will break the environmental seal and potentially cause improper stop limit settings. This will void the warranty.

Section 1 Introduction

Review this manual in its entirety. Contact the Will-Burt Company with any questions before performing any procedure outlined in this manual.

The PositionIt™ system is a pan and tilt positioner system used as a platform for many different applications. This system is designed to remotely position a suitable payload and may be attached on top of a mast. This manual covers the following models of PositionIt:

- PI-35 (P/N: MM233TX2TXRX2)
- PI-75 (P/N: HM211TXXDXRX2)
- PI-150 (P/N: HM211TX2DXRX2)

The PositionIt does not currently support the following:

- GPS Control
- Infrared Remote Control
- RS-232 GUI Interface (customer supplied only)
- Mast Up / Down Control

1.1 Safety Precautions

Refer to the Safety Summary for precautions to be observed while installing, operating, maintaining, or troubleshooting this equipment.

1.2 How this Manual is Organized

This manual is organized into the following sections:

Section 1 Introduction

Section 2 Installation

Section 3 Operation

Section 4 Maintenance

Section 5 Troubleshooting

Section 6 Appendix

Section 7 Drawings

1.3 Additional Documentation

In addition to this manual, the controller ships with the controller manual. Reference this manual for additional information on the function of the controller.

1.4 Definitions of Terms and Symbols

Throughout this manual, the following will be used:

General Terms:

- Positioner refers to the PositionIt (PI-35, PI-75 & PI-150).
- Controller refers to the default joystick controller (P/N: 5098901).
- System refers to the entire positioner and controller system.
- Payload refers to the object or equipment being moved by the positioner.

Positions

- Home (Figure 1-1) to refer to the factory set preset position [0] (zero) which is set to move the positioner to the mid-point of both the pan and tilt. In this position, the tilt platform will be horizontal, and the pan axis will be in the center position. In this position, the rear of the positioner is the side facing the side egress on the mounting pedestal. Note that the offset on the left of the positioner, as you face the side egress, is wider than the offset to the right. The positioner ships in the home position.

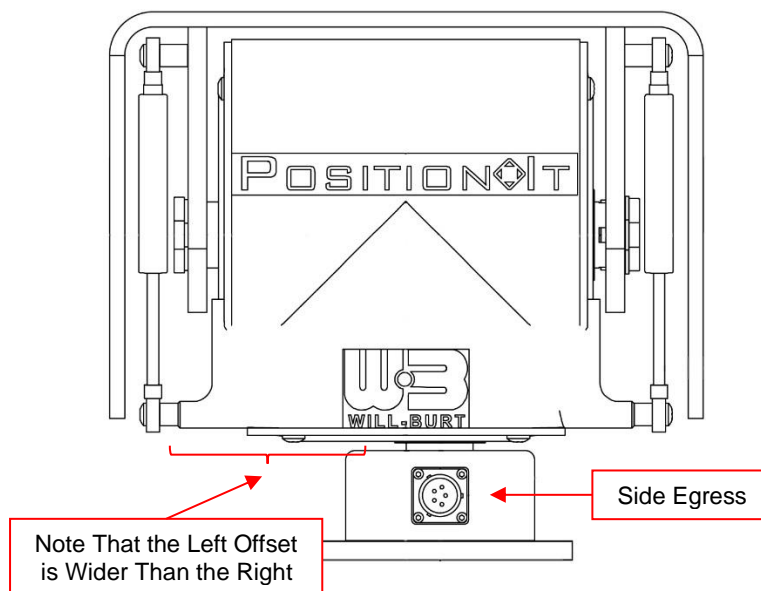

Figure 1-1 Home Position (PI-150 Shown)

- Stowed refers to a customer-set preset position which the positioner moves the payload to a desired pan and tilt position for travel or safe storage. The customer should set this as preset [1].
- Unstowed refers to a customer-set preset position which the positioner moves the payload to a desired pan and tilt position from the stowed position. The customer should be sure the positioner can be safely moved to this position from the stowed position without causing damage. The customer should set this as preset [2].

Directions

- When operating the positioner, directions are given as follows:

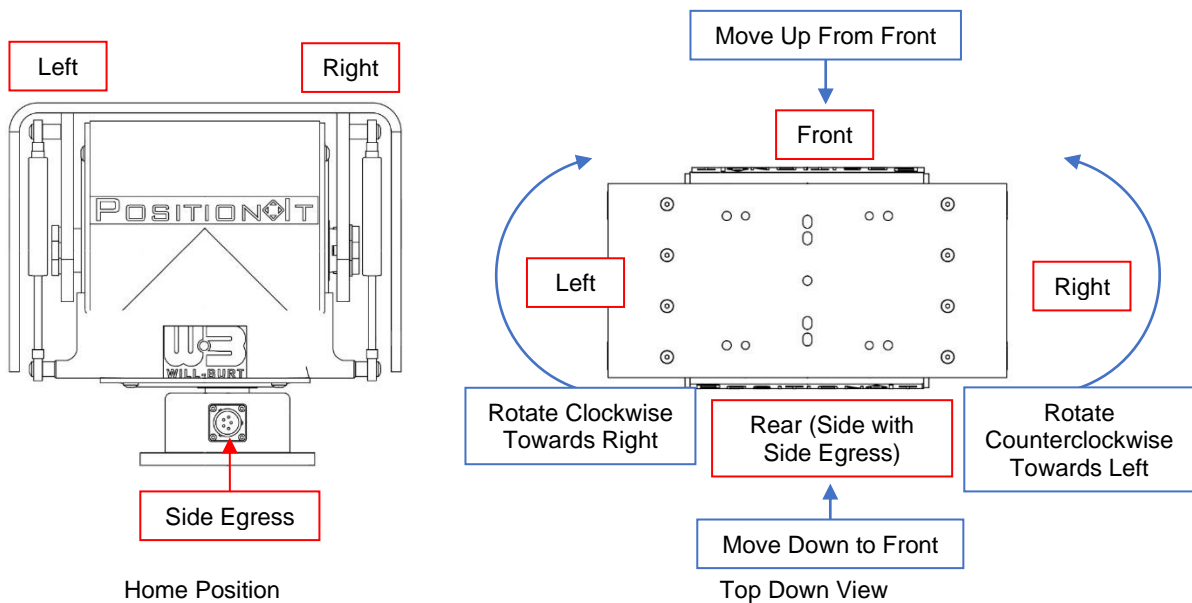

Figure 1-2 Positioner Directions (PI-150 Shown)

- When using the default joystick:
 - Pushing the joystick forward will tilt the positioner towards the rear
 - Pulling the joystick back will tilt the positioner towards the front
 - Moving the joystick to the right will rotate the joystick clockwise
 - Moving the joystick to the left will rotate the joystick counterclockwise

Symbols:

- Characters inside < > as in <Success!> represent text that appears on the display screen.
- Characters inside [] as in [1] represent buttons or keys being used.
- Arrows as in “▲, ►, ▼, ◀” represent the direction(s) the positioner is moving in. These arrows are shown on the display screen of the default joystick controller (P/N: 5098901).

1.5 Specifications

Table 1-1 lists specifications for the positioner. Table 1-2 lists specifications for the default joystick controller.

Table 1-1 Positioner Specifications

	PI-35	PI-75	PI-150
Payload Capacity	35 ft.-lb. (47 Nm)	75 ft.-lb. (101 Nm)	150 ft.-lb. (202 Nm)
Overall Height	9.8 in. (248mm)	11.32 in. (287.7 mm)	11.32 in. (287.7 mm)
Overall Width	10.8 in. (273mm)	9.7 in. (246.0 mm)	12.4 in. (314.0 mm)
Weight	21 lb. (9.5kg)	35 lb. (15.9 kg)	37 lb. (16.8 kg)
Operating Temperature	-40°F to 140°F (-40°C to 60°C)		
Pan Degrees of Rotation	± 400° (± 200°)		
Tilt Degrees of Rotation	180° (± 90°)		
Pan Speed (Proportional)	1 to 12° / second	1 to 6.5° / second	
Tilt Speed (Proportional)	1 to 12° / second	1 to 5.5° / second	
Backlash	≤ 0.15°		
Repeatability	≤ 0.3°		
Maximum Continuous Power	44 W		
Maximum Continuous Current	1.85 amps		
Input Voltage	24 VDC		
Protocol	Pelco D used (Pelco P available)		
Ingress Protection Rating	IP68		
Baud Rate	2,400 bps		

Table 1-2 Default Joystick Controller (P/N: 5098901) Specifications

Specifications	
Input Voltage	12 VDC
Rating Power	0.5 watts
Communication Interface	RS485
Communication Frequency	2,400 bps used (4,800; 9,600; 19,200 bps available)
Operating Temperature	32°F to 122°F (0°C to 50°C)
Dimensions (W x H x L)	5.4 x 4.2 x 6.6 in. (136 x 105 x 168 mm)
Weight	0.89 lb. (0.40 kg)
Protocol	Pelco D used

1.6 Major Components

The major components of the system are:

- Positioner
- Controller
- Power/Data Cable
- Positioner Power Supply
- Step Up Converter
- Step Down Converter

1.6.1 Positioner

The positioner comes in (3) models, the PI-35 (P/N: MM233TX2TXRX2), PI-75 (P/N: HM211TXDXRX2) and PI-150 (P/N: HM211TX2DXRX2).

The pan and tilt positioner:

- Is made of die-cast aluminum casing
- Uses stainless steel fasteners
- Has weather and dust proofing to an IP68 rating
- Is designed to minimize backlash
- Is configured to run on RS485 data using Pelco D protocol
- Contains an internal tether to prevent the pan and tilt head from separating from the mast in the event of an impact load separating the pan and tilt head from the base
- Ships with the PositionIt Operator's Manual (this manual)



Figure 1-3 Positioners

1.6.2 Controller

The default joystick controller (P/N: 5098901) (Figure 1-4):

- Controls pan and tilt functions
- Is Pelco D compatible
- Has a joystick, LCD Screen and a keyboard
- Has programmable presets
- Has programmable electronic limits
- Has speed control
- Ships with the controller manual
- Is not designed to handle inclement weather and should be kept in a protected environment



Figure 1-4 Default Joystick Controller (Left: With Keyboard Cover On. Right: With Keyboard Cover Off.)

1.6.3 Power/Data Cable

The power/data cable (Figure 1-5) consists of (2) power wires (16 AWG twisted pair) and (2) control wires (22 AWG twisted pair). The cable ships with a straight connector (PT06W14-5S) installed on one end and loose wires on the other end to allow for a Nycoil pull. The end with the loose wires can be cut if the customer requires a shorter length.

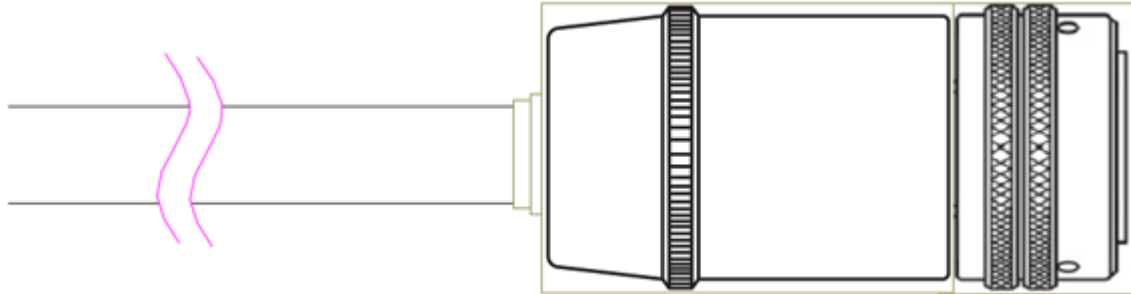

Figure 1-5 Power/Data Cable

Table 1-3 provides the part numbers for the standard cables.

Table 1-3 Standard Cables

Will-Burt Part Number	Length
5611601	35 ft. (10 m)
5611602	66 ft. (20 m)
5611603	99 ft. (30 m)

1.6.4 Positioner Power Supply

The positioner power supply (P/N: 208016) (Figure 1-6) is used in systems using 120 VAC (50 or 60 Hz) or 240 VAC (50 or 60 Hz) to convert the AC power to 24 VDC input power for the positioner. The power supply has short circuit, overcurrent, overvoltage, and over temperature protections. It is an IP67 design and is suitable for dry, damp, or wet locations.



Figure 1-6 Positioner Power Supply

1.6.5 Barrel Connector (2.1 mm)

The 2.1 mm barrel connector (P/N: 5195601) (Figure 1-7) can be used to connect the controller to the step down converter or 12 VDC power source.



Figure 1-7 Barrel Connector

1.7 Quick Overview

This section provides a quick overview of the system. Be aware of and follow all associated precautions when performing these procedures.

To install the positioner (Section 2):

1. Mount the positioner with (4) high-strength $\frac{3}{8}$ in. or M8 stainless steel bolts and nuts. See Section 2.5 for additional detail and bolt pattern.
2. Wire the positioner according to the schematic (Section 7). See Section 2.6 for additional detail.
3. Mount the payload with appropriate hardware. See Section 2.7 for additional detail.

To operate the positioner (Section 3):

1. Attach the controller.
2. Operate the positioner using the controller. See Section 3 for additional detail on the function of the default joystick controller (P/N: 5098901).
3. If required, see Section 3.3.7 for information on how to use preset positions.
4. If required, see Section 3.3.8 for information on how to adjust the electronic limit stops. The positioner ships from the factory with electronic limit stops set. There are no hard stops.

(This page is intentionally left blank.)

Section 2 Installation

This section describes the installation of the system and provides general procedures that must be followed to ensure a successful installation.

2.1 Pre-Installation Check

Before installing the system:

- Be sure to read and understand the entire installation procedure before beginning installation.
- Ensure that only a properly trained and qualified certified electrician performs electric installations and maintenance.
- All required tools are readily available.
- That the following warnings are understood and followed:

⚠ WARNING

Mounting Structure Hazard! Before installation, be certain the mounting structure is capable of resisting forces generated from all loading and environmental conditions including, but not limited to system size and weight, payload size and weight, sail size, and wind speed. Mounting the system to a structure unable to resist the forces generated from customer-specific loading scenario could result in death or serious injury and could damage the system.

⚠ WARNING

Safety Instruction – Mounting Instructions! Be sure to understand all mounting instructions. The mounting hardware must include proper means to resist vibration loosening such as thread-locking compound or locking hardware. Failure to follow mounting instructions can result in death or injury.

⚠ WARNING

Trained Personnel Only! Only trained and qualified personnel should perform installation, adjustments, and servicing. Only a properly trained and qualified certified electrician should perform electric installations and service. Death or serious injury could result if proper installation, inspection, operation, and maintenance procedures are not observed.

⚠ CAUTION

Equipment Damage! Only mount the positioner so that the positioner base faces down. Do not mount the positioner upside down. Failure to follow mounting instructions can result in damage to the positioner.

2.2 Installation Tools

Table 2-1 lists tools and materials recommended for installation.

Table 2-1 Tools and Materials Recommended for Installation

Tools and Materials		
Safety Glasses	Safety Gloves	Safety Shoes or Combat Boots
Hard Hat or Helmet	Wrenches	Screwdrivers
Wire Cutter / Stripper	Crimping Tools	Mounting Hardware (Payload)
Level	Soldering Kit	Mounting Hardware (Pedestal)
Thread-Locking Compound or Locking Hardware		

2.3 Components

When unpacking, check to ensure all ordered components have arrived. The components your system includes will vary based upon your order.

Possible components include:

- Positioner (PI-35, PI-75 or PI-150)
- Controller
- Controller Manual (ships with controller)
- PositionIt Positioner Operator's Manual (this manual)
- Power/Data Cable (used to connect positioner to the controller and the power supply)
- Some combination of the following:
 - Positioner Power Supply (used in systems with AC input power)
 - Step Up Converter (used in systems with 12 VDC input power)
 - Step Down Converter (used in systems with 24 VDC input power)
- Barrel Connector (2.1 mm) (used to connect the controller to the power supply)

2.4 Unpacking

Unpack as follows:

1. Carefully open the box(es) and unpack all components.
2. Check for any damage from shipping. If damage has occurred, notify the carrier.
3. Ensure that all required tools are readily available.

2.5 Mounting the Positioner

When installing, the front of the positioner can be identified as the side of the positioner opposite of the side egress on the mounting pedestal while the positioner is in the home position (Figure 2-1). Note that the offset on the left of the positioner, as you face the side egress, is wider than the offset to the right. The positioner ships in the home position.

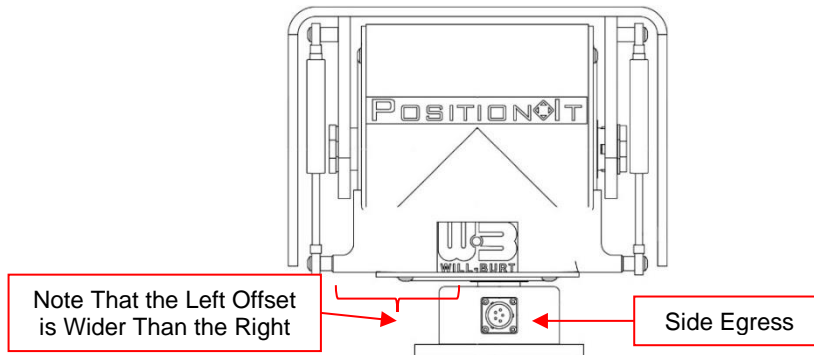

Figure 2-1 Rear of Positioner (PI-150 Shown)

The mounting location must:

- Be capable of withstanding the holding forces required by the bolts
- Be located on level terrain
- Be free of obstructions
- Allow for full pan and tilt movement
- Have the positioner base face down. Do not mount the positioner upside down.

Be sure to take into consideration other external factors, such as wind or ice loading, when selecting a mounting location. Make sure that these external factors do not overload the system.

Reference Figure 2-2 for the mounting hole locations for the system. There are (4) holes equally spaced. Connect the positioner to the top of the mast with (4) high-strength $\frac{3}{8}$ in. or M8 stainless steel bolts and nuts (customer supplied). Torque all hardware as appropriate for its material and size. The mounting hardware must include proper means to resist vibration loosening such as thread-locking compound or locking hardware.

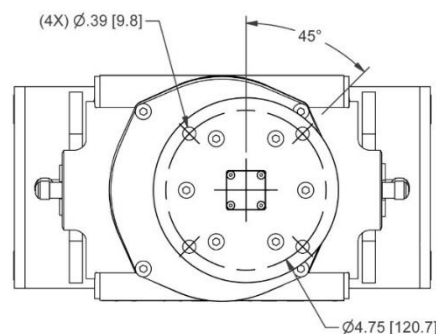

Figure 2-2 Positioner Mounting Hole Pattern (See Section 7 for Enlarged version)

2.6 Wiring the System

This section discusses wiring the system assuming the default joystick controller (P/N: 5098901) is being used.

2.6.1 Positioner Plugs

The positioner has (2) plug locations on the mounting pedestal for wiring. The side egress (Figure 2-3) on the mounting pedestal ships from the factory with a removable plug installed. The bottom egress on the mounting pedestal ships from the factory with a plug plate installed. To use the bottom egress, the plug plate and the removable plug must be swapped. If either egress is not properly sealed, the positioner will leak and become damaged voiding the warranty.

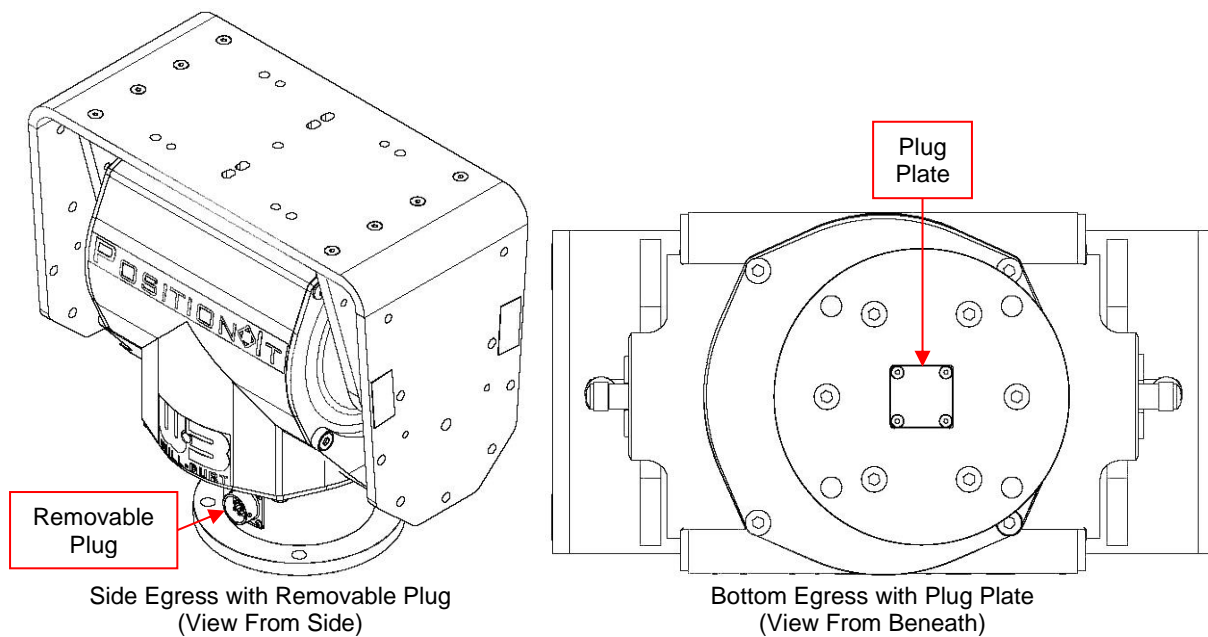

Figure 2-3 Positioner Plug Locations (PI-150 Shown)

To use the bottom egress:

1. Ensure there is no power to the positioner.
2. Loosen the (4) bolts securing the removable plug to the side of the mounting pedestal.

- Carefully pull away the removable plug and gently pull out the attached wires and gasket behind it (Figure 2-4).

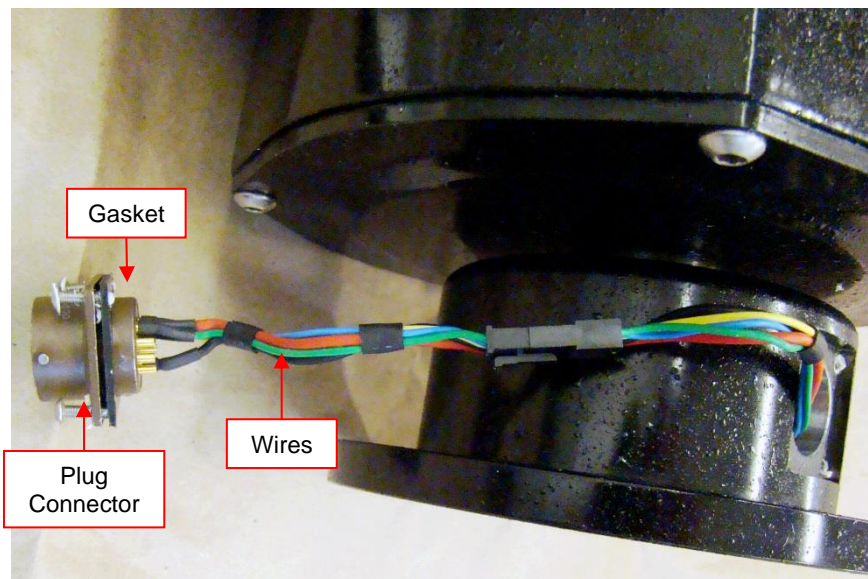

Figure 2-4 Carefully Pull Out the Removable Plug, Gasket, and Attached Wires

- Disconnect the wires from the positioner. The wires are connected to the positioner with a quick connect (Figure 2-5).

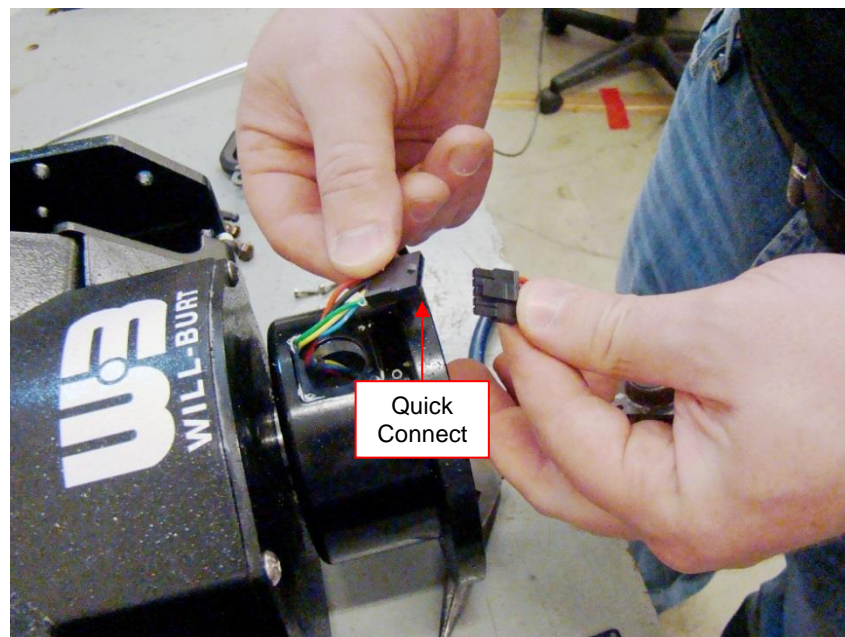

Figure 2-5 Quick Connect

5. Remove the (4) bolts securing the plug plate to the bottom of the mounting pedestal (Figure 2-6).

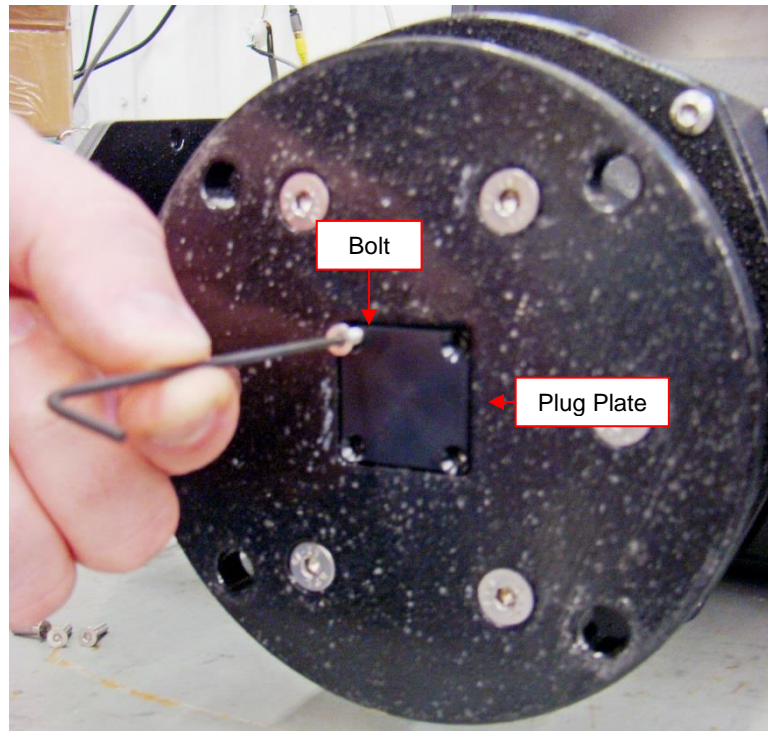

Figure 2-6 Remove the (4) Bolts Securing the Plug Plate

6. Remove the plug plate and the gasket behind it (Figure 2-7). Set the gasket and plug plate aside.

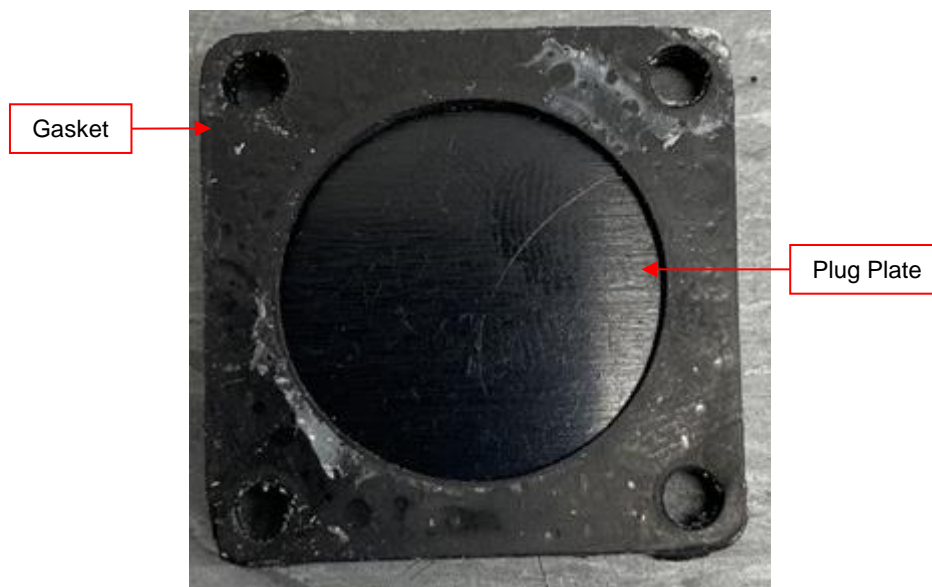

Figure 2-7 Remove Plug Plate and Gasket

7. Pull the wires still in the positioner through the hole at the side egress.

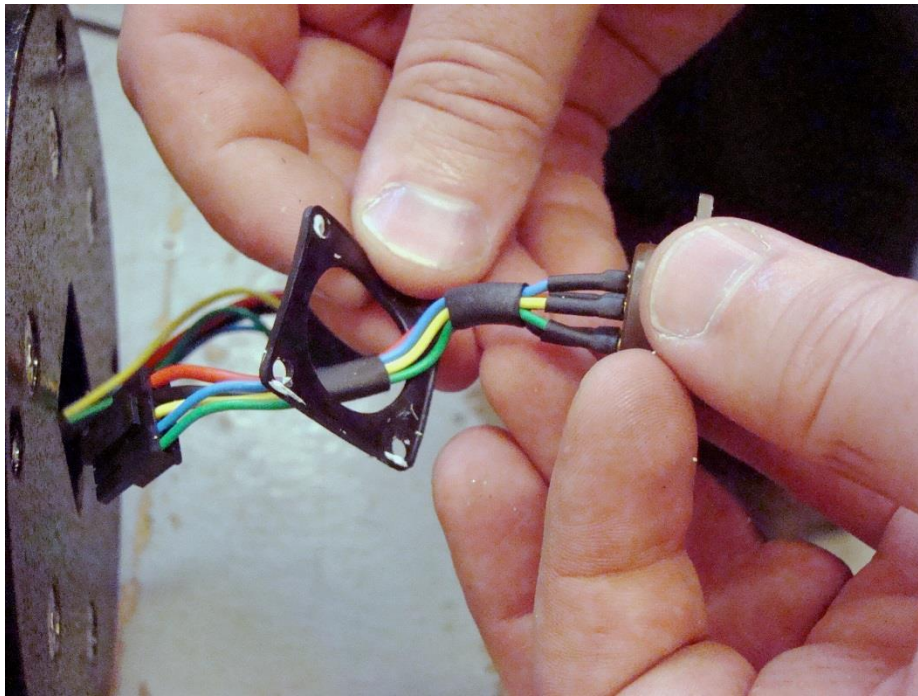

Figure 2-8 Pull the Wires out the Bottom of the Positioner

8. Reconnect the quick connect between the wires from the positioner and the plug making sure the gasket is in place.
9. Gently push the wires into the positioner and secure the gasket and removable plug in place at the bottom of the mounting pedestal (Figure 2-9). If the gasket is not properly installed, the positioner will leak and become damaged voiding the warranty.

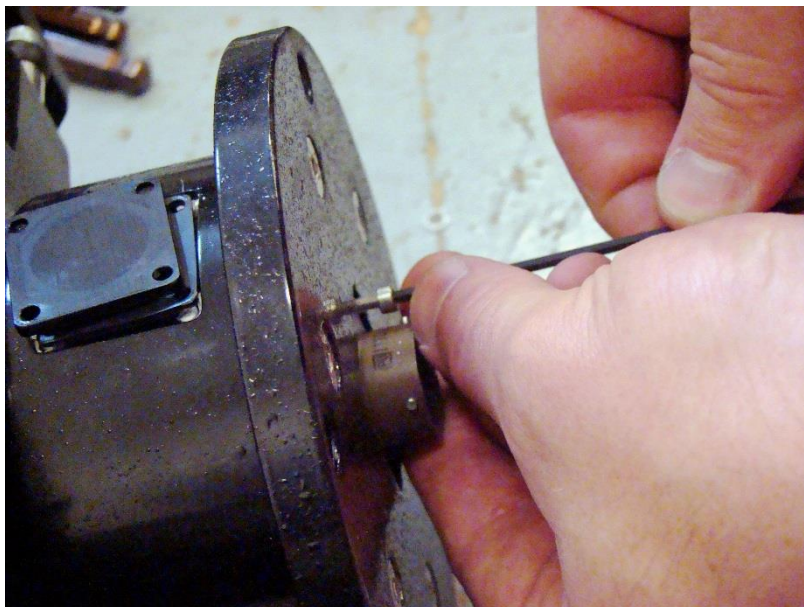

Figure 2-9 Secure the Gasket and Removable Plug to the Bottom Egress

10. Secure plug plate and its gasket at the side egress where the removable plug had previously been installed from the factory (Figure 2-10). If the gasket is not properly installed, the positioner will leak and become damaged voiding the warranty.

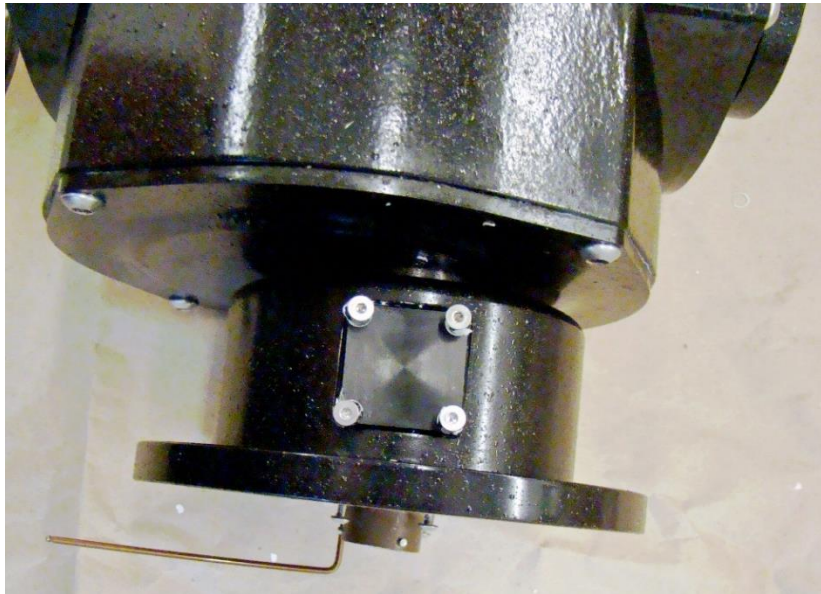

Figure 2-10 Secure the Plug Plate and Gasket to the Side Egress

11. Check to ensure both plug locations are properly sealed. If either plug location is not properly sealed, the positioner will leak and become damaged voiding the warranty.

2.6.2 Connecting Power and Controls

This section describes how to connect the power and controls to the system.

⚠ CAUTION

Equipment Damage! Ensure the connections are made properly to prevent water ingress into the positioner through the connections. Should water enter the positioner, extreme problems can occur.

Depending on the configuration of your system, power and controls can be hooked up several different ways. Select the appropriate method for your system and wire accordingly:

- Powered with 12 VDC
- Powered with 24 VDC
- Powered with 120 VAC (50 or 60 Hz) or 240 VAC (50 or 60 Hz)

Powered with 12 VDC:

The positioner runs on 24 VDC and power other than 24 VDC must be converted to 24 VDC for the positioner.

If the input power supply is 12 VDC, the system will require:

- A step up converter from 12 VDC to 24 VDC to power the positioner
- A connector (P/N: 5195601) to connect 12 VDC to the controller

Figure 2-11 provides a quick overview of the wiring for a system powered with 12 VDC input.

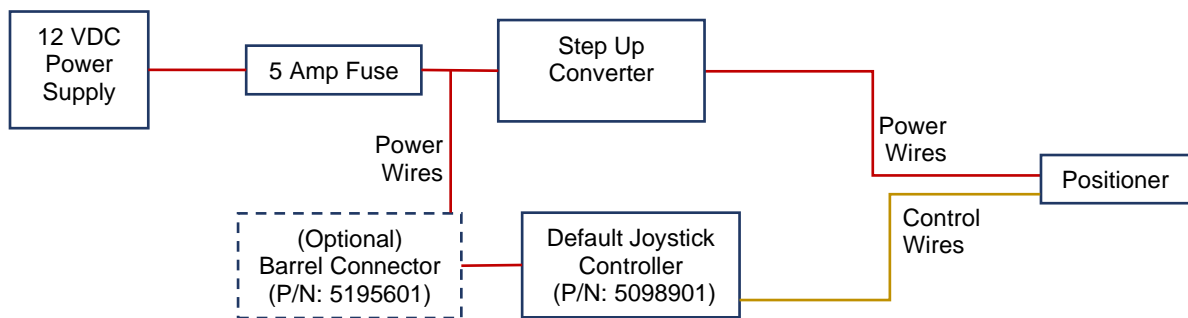

Figure 2-11 Powered with 12 VDC

To wire the positioner using 12 VDC:

1. Connect the 5-pin plug (attached to the power/data cable) to the positioner.
2. Twist the plug to the right to secure the connection.
3. Run the 22 AWG green (data A, +) and white (data B, -) wires from the power/data cable to the controller.
4. Run the 16 AWG red (power) and black (ground) wires from the power/data cable to the step up converter.
5. Run the 12 VDC power to the controller and the step up converter. Run a (5) amp slow blow fuse (customer supplied) inline between the power supply and the controller and step up converter. An optional DC cable connector may be used to connect the controller and the power supply.

Powered with 24 VDC:

The default joystick controller (P/N: 5098901) runs on 12 VDC power. To run 24 VDC systems, this must be stepped down to 12 VDC.

If the input power supply is 24 VDC, the system will require:

- A step down converter from 24 VDC to 12 VDC to power the controller (if the AC power supply that comes with the controller is not used)
- A connector (P/N: 5195601) to connect 12 VDC to the controller (if the AC power supply is not used)

Figure 2-12 provides a quick overview of the wiring for a system powered with 24 VDC input.

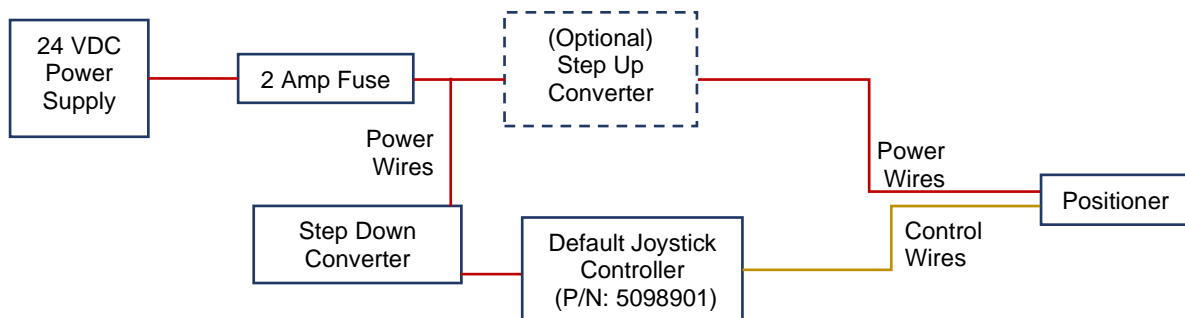

Figure 2-12 Powered with 24 VDC

To wire the positioner using 24 VDC:

1. Connect the 5-pin plug (attached to the power/data cable) to the positioner.
2. Twist the plug to the right to secure the connection.
3. Run the 22 AWG green (data A, +) and white (data B, -) wires from the power/data cable to the controller.
4. Run the power wires from the controller to the step down converter.
5. Wire the step down converter and the 16 AWG red (power) and black (ground) wires from the power/data cable to the 24 VDC power supply. Run a (2) amp slow blow fuse (customer supplied) inline between the power supply and the positioner and the step down converter. An optional DC to DC converter can be run inline between the power supply and the positioner to help maintain 24 VDC under low voltage situations.

Powered with 120 VAC (50 or 60 Hz) or 240 VAC (50 or 60 Hz):

The positioner runs on 24 VDC and power other than 24 VDC must be converted to 24 VDC for the positioner. The default joystick controller (P/N: 5098901) comes with its own power supply for the VAC input which is transformed to 12 VDC.

If the input power supply is VAC, the system will require:

- A power supply (P/N: 208016) for the positioner
- The existing joystick cable to power the joystick

If the customer is using AC input power and the power supply (P/N: 208016), the customer is responsible for installing a plug (customer-supplied) based on their region. The power supply ships with loose wires to connect to the appropriate customer supplied plug.

Figure 2-13 provides a quick overview of the wiring for a system powered with AC input.

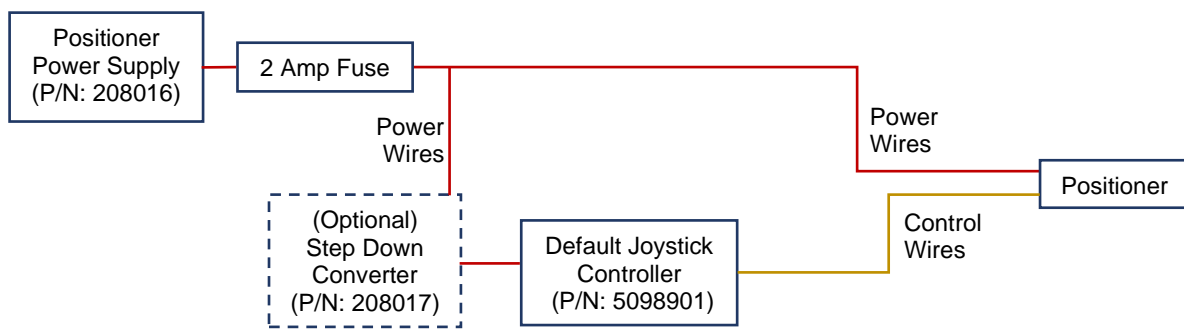

Figure 2-13 Powered with VAC

To wire the positioner using VAC:

1. Connect the 5-pin plug (attached to the power/data cable) to the positioner.
2. Twist the plug to the right to secure the connection.
3. Run the 22 AWG green (data A) and white (data B) wires from the power/data cable to the controller.
4. Wire the 16 AWG red (power) and black (ground) wires from the power/data cable and the controller to the positioner power supply. Run a (2) amp slow blow fuse (customer supplied) inline between the positioner power supply and the positioner and controller. An optional step down converter can be run between the controller and the positioner power supply.

2.7 Mounting the Payload

This section discusses mounting the payload.

⚠ WARNING

Safety Instruction – Mounting Instructions! Before operation, be certain the positioner is capable of resisting forces generated from all loading and environmental conditions including, but not limited to payload size and weight, sail size, and wind and ice loading. The mounting hardware must include proper means to resist vibration loosening such as thread-locking compound or locking hardware. Mounting the payload into a positioner unable to resist the forces generated from the customer-specific loading scenario could result in death or serious injury, and could damage the positioner.

To attach the payload:

1. Ensure power to the system is off while installing the payload.
2. Reference the mounting hole patterns for the payload:
 - Figure 2-14 PI-35 Payload Mounting Hole Pattern
 - Figure 2-15 PI-75 Payload Mounting Hole Pattern
 - Figure 2-156 PI-150 Payload Mounting Hole Pattern
3. Position the payload on the mounting plate.
4. Connect the payload to the top of the positioner with appropriate hardware. Torque all hardware as appropriate for its material and size. The mounting hardware must include proper means to resist vibration loosening such as thread-locking compound, or locking hardware.

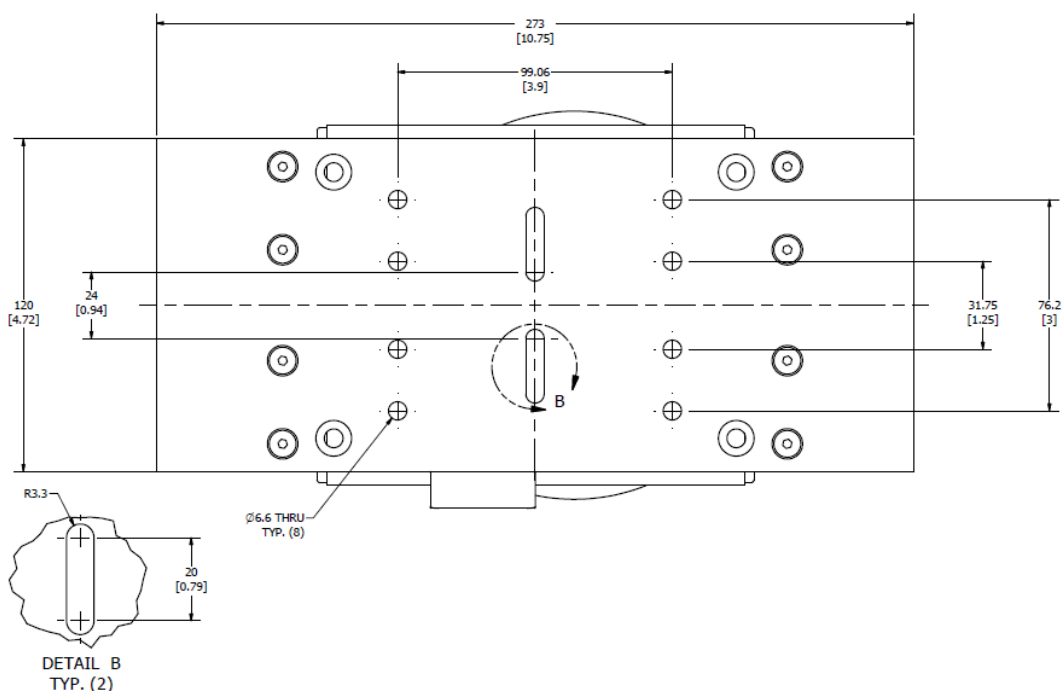

Figure 2-14 PI-35 Payload Mounting Hole Pattern

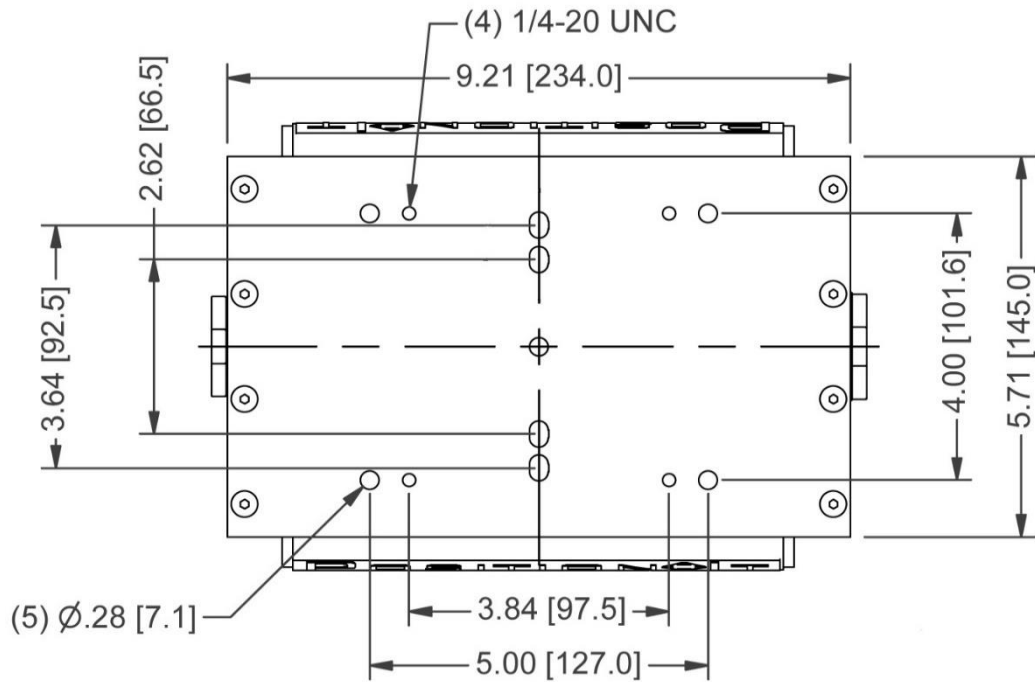

Figure 2-15 PI-75 Payload Mounting Hole Pattern

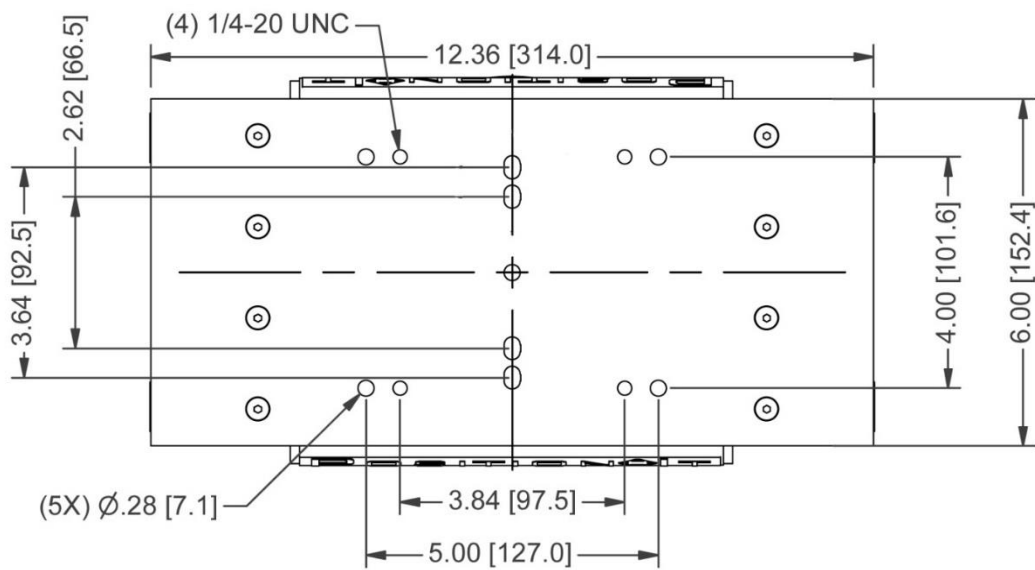

Figure 2-156 PI-150 Payload Mounting Hole Pattern

2.8 Setting Presets and Electronic Limit Stops

Electronic limit stops can be set within the positioner as part of the installation process. Setting electronic limit stops prevents the positioner from travelling past a specified point in either tilt or pan direction. The user has the option to set electronic limit stops for the tilt up, tilt down, pan right and/or pan left directions. Electronic limit stops can be cleared by the user. Electronic limit stops can be set and cleared using a Pelco D compatible joystick controller or a GUI. Electronic limit stops are assigned by setting presets 80, 81, 82 and 83. Electronic limit stops are cleared by setting presets 70, 71, 72 and 73. See Sections 3.3.7, Electronic Limit Stops3.3.8**Error! Reference source not found.**, and 6.2.

IMPORTANT! If the tilt limit stops are cleared to their default settings, it is possible to drive the payload platform into the power/data connector. This will cause damage to the positioner.

Presets can be set within the positioner to store a specified position. The user can store [1] - [50] presets. Presets can be cleared or over overwritten. Presets can be set, cleared, or overwritten using a Pelco D compatible joystick controller or a GUI. Preset [0] is designated for the “Factory Home” position and cannot be reset. Preset [1] and Preset [2] is designated for the “Stow” and “Unstow” position and are set by the user. See Sections 3.3.7 and 6.2 for more details.

Section 3 Operation

This section describes the operation of the system.

3.1 Pre-Operation Check

Before operating the system:

- Be sure to read and understand the entire operation procedure before beginning operation.
- Visually inspect the system for damage. If damage is apparent, do not use the system, and have it serviced prior to use.
- Read and understand the controller manual. Ensure that all warnings, associated with the controller are understood and followed. Ensure all relevant installation, operation, and maintenance instructions are followed.
- Ensure that the area around the pan and tilt area is clear so no damage will result from unexpected movement.
- Ensure that all wiring connections are tight and appropriately connected.
- Ensure that the following warnings are understood and followed:

⚠ WARNING

Tip Over Hazard! Do not operate in high winds. Operate on level ground only. Stand clear of positioner and payload during operation. Be certain positioner is level and secure. System tip over could result in death or serious injury.

⚠ WARNING

Safety Instruction – Operation! For outdoor use only. Do not use in areas that have been classified as hazardous.

⚠ WARNING

Safety Instruction – Keep Clear! Keep personnel clear of the positioner during operation.

⚠ CAUTION

Equipment Damage! Check for and remove any objects which might obstruct motion, cause binding, or hinder function of the system. Hitting obstructions will cause damage to the positioner.

⚠ CAUTION

Equipment Damage! If the electronic tilt limit stops are reset to their original settings, it is possible to drive the payload platform into contact with the positioner. Damage to the positioner and payload will occur.

⚠ CAUTION

Entanglement Hazard! Ensure cables are not tangled and are free to play out as the mast is extended. Tangled cables can cause equipment damage.

3.2 Operation Tools

Table 3-1 lists tools and materials recommended for operation

Table 3-1 Tools and Materials Recommended for Operation

Tools and Materials		
Safety Glasses	Safety Gloves	Safety Shoes or Combat Boots
Hard Hat or Helmet		

3.3 General Controls

The information and instructions described in this section are for the default joystick controller (P/N: 5098901) for the system. Refer to the controller manual for information on the specific controller with your system. Some functions of the default joystick controller are not used with the positioner.

The default joystick controller is not designed to handle inclement weather and should be kept in a protected environment. When the controller is in operation, the LCD screen backlight will turn on. The keyboard and joystick can be used to access menu functions, adjust electronic limit stops, and store and recall preset positions.

The front of the positioner can be identified as the side of the positioner opposite the side egress on the mounting pedestal while the positioner is in the home position. The positioner ships in the home position.

The positioner is also designed to be used with PC, Laptop, Tablet, etc. via the use of the GUI however the GUI is primarily used to access configuration functions. Below are the installation and control instruction for all options.

3.3.1 GUI Installation

To install a new version of the GUI on you selected device (PC, Laptop, Tablet, etc.) you must first uninstall any previous version located on the device that you are installing to.

A copy of the most up to date GUI will be provided with the Positioner.

3.3.2 GUI Setup Instructions

3.3.2.1 Easysync Setup.

- Connect 1x Easysync ES-U-3001-M Unit to your Laptop/ PC/ Tablet using the USB connection cable.
 - Set to RS485 Half duplex by switching the white Dip Switches on the Easysync unit.
 - Settings: Up/Dn/Dn/Dn
 - Connect the Data A & B cables from the positioner to ports 1 & 2 on the Easysync unit.

3.3.2.2 WB Positioner Setup.

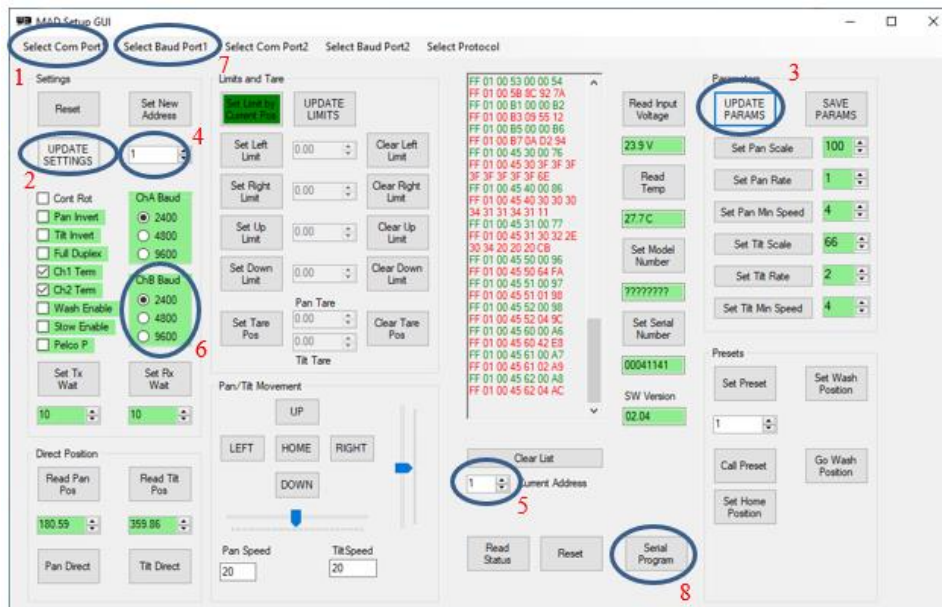

Figure 3-1 GUI Layout

- Press the “Select Com Port 1” drop down menu and select the Com Port the unit/ converter is connected to.
- Press “UPDATE SETTINGS” for the unit to update all the necessary settings, the GUI will start updating the settings and this process should take approximately 30 seconds. Once the settings are updated all the boxes underneath the “UPDATE SETTINGS” and “Read Input Voltage” will go green.
- If the sections do not go green as shown in figure 3-1 above, then swap the connection of Data cables A & B which are in port 1 & 2 on the Easysync unit.
- Press “UPDATE PARAMS” which will update all the parameters set. Once all the parameters are updated all the boxes underneath the “UPDATE PARAMS” will go green.
- To change the address of the unit, enter the address number within the box shown in the picture above marked as 4 and press “Set New Address” to save the setting onto the unit.

- The current address will change to the one set however if the GUI is restarted the current address must be changed to the set address of the unit.
- To change the baud rate of the positioner, select the required Baud Rate from the “ChB Baud” section shown in figure 3-1.
- To drive the unit using the GUI the Baud Rate from the dropdown menu “Select Baud Port1” must also be changed as per the set Baud rate on the unit.
- To reprogramme the PCB select the “Serial Program” button from the GUI and follow the instruction in section 3.3.3 below.

3.3.2.3 Presets and Stow & Unstow Setup

Preset positions can be stored to a preset number between (1) and (50).

The positioner comes from the factory with the preset [0] (zero) set to move the positioner to the mid-point of both the pan and tilt. In this position the tilt platform will be horizontal and the pan axis will be in the center position. This is referred to as the Home position.

The customer can program a stowed position by setting preset position [1]. The customer can program an unstow position by setting preset position [2].

Presets can be set or recalled using the GUI. Presets can be cleared through the GUI.

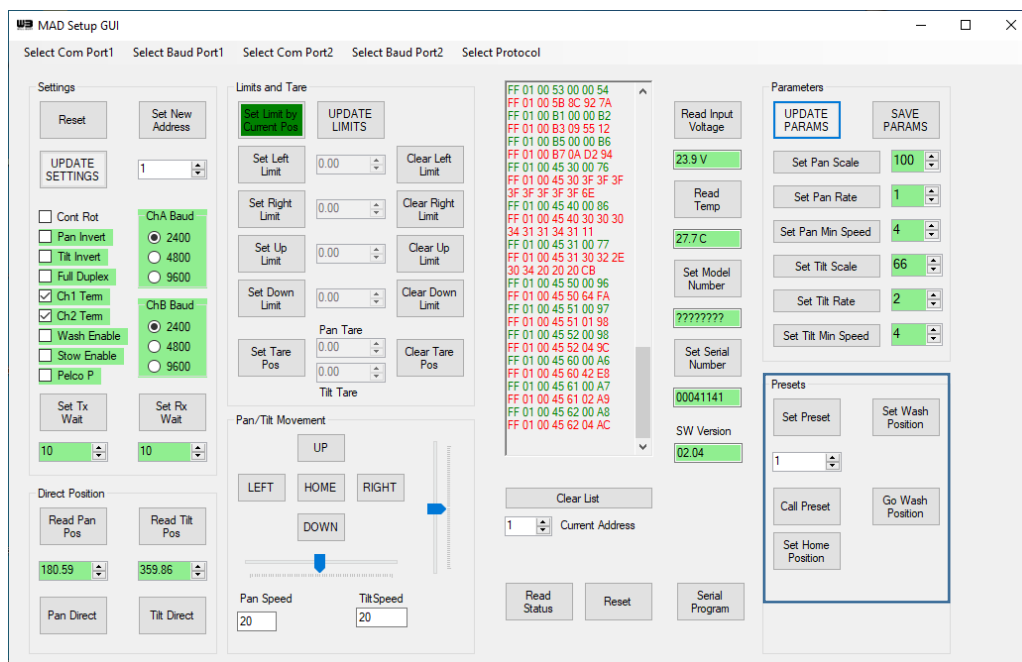

Figure 3-2 Preset Configuration

3.3.3 PCB Reprogramming Instructions

3.3.3.1 RS232 Connection & Setup

- Programming should be carried out by a competent operator with advanced knowledge of firmware installation. If in doubt, contact Will-Burt customer service.

IMPORTANT! Incorrect installation of firmware may render the PCB unusable which will then require a factory reset.

- A programming lead would be required to reprogramme the unit, which can be bought through Will Burt. Please contact Will Burt sales representative if a programming lead is required.
- Loosen the (4) bolts securing the removable plate to the back of the unit.

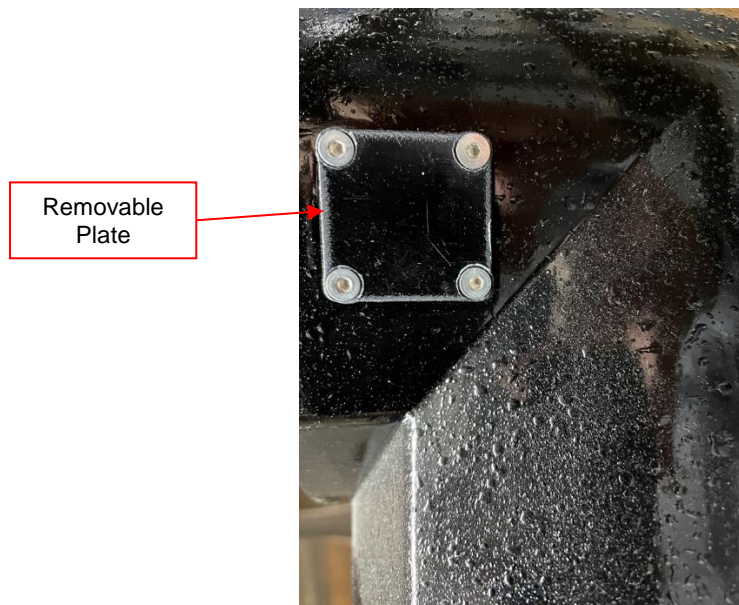

Figure 3-3 Removeable Plug Location

- Gently pull the plate to gain access to the internal programming lead connected to the internal PCB.
- Connect the connector end on the programming cable to internal programming lead attached to the removeable plate.
- Connect the serial port plug end on the programming cable to the serial port on the Easysync ES-U-3001-M Unit.
- Using the USB connection cable connect the Easysync to your Laptop/ PC/ Tablet.
 - Set to RS232 by switching the white dip switches on the Easysync unit.
 - Settings: Dn/Up/Up/Up

3.3.3.2 Program Instructions

- Before programming the unit, the unit has to be put in “Serial Program” Mode which can be done using the GUI, please refer to section 3.3.2.2 for instructions.
- Open Flash Magic Program.
 - In the Device section:
 - Setting: Device to be set to LPC 1768 (this is the GEN 2 PCB Type)
 - Setting: COM Port X, this may vary, depending on the available ports on your Laptop/ PC/ Tablet
 - Setting: Baud Rate to be set to 57600
 - In the Firmware Section:
 - Click the browse button and navigate to your selected Hex file. (New Hex file firmware to be installed on the PCB).
 - In the Options Section:
 - Check the verify after programming box.
 - Click Start button.
 - *Wait for verification to complete (Bottom left corner)*
 - Perform a power cycle on the PCB (shut off or disconnect power to the Positioner unit for 10 sec).
 - Re-connect and restart power to the Positioner.
 - Switch back to the WB Positioner Setup GUI (3.3.2.2)
 - In the settings box Click Update settings button.
 - *Wait for all boxes to turn green*
 - Click “UPDATE PRAMS” Button
 - *Wait for all boxes to turn green*
 - Click “SAVE PRAMS” button.
 - The software version box “SW Version” box would have changed to the updated version.
 - Confirm movement of the positioner.

NOTE:

To install a new version of the WB Positioner Setup PROGRAM on you selected device (PC, Laptop, Tablet, etc.) you must first uninstall any previous version located on the device that you are installing too.

3.3.4 Keyboard

The controller contains functions and keys which are not used with the positioner. Keys (Figure 3-) which are used for operation include:

- [Menu] which is used to access menu functions
- [Ent] (enter) which is used to make selections within the menu
- [Set] which is used in the process to store presets and electronic limit stops
- [Pre] (preset) which is used in the process to store presets and electronic limit stops, and in the process to recall presets
- [Mon] (monitor) which is used in the process to change the MonID
- [Cam] (camera) which is used in the process to change the CamID

- [Prev] (previous) which is used when using the menu to save preset positions, and to cancel out of a preset without recalling it
- [N], where “N” represents a number on the keyboard, which is used to access menu functions, and as part of the processes to store and recall presets



Figure 3-4 Keyboard Keys

3.3.5 Joystick

The joystick pans and tilts the positioner. The speed of the movement will directly relate to the lean angle of the joystick.

Menu

When used with menu functions, the joystick controller functions as follows:

- Push the joystick forward to move up the menu
- Pull the joystick back to move down the menu
- When the joystick is moved to the right, the menu will go to the sub menu or save the setup
- When the joystick is moved to the left, the menu will be exited

Panning and Tilting

When moving the positioner with the joystick, arrows pointing in the direction of the movement will display in the lower right corner of the LCD screen. The greater the lean of the joystick, the faster the movement. Viewed from the front, clockwise movement is to the left, and counterclockwise movement is to the right.

When panning and tilting, the joystick functions as follows:

- When the joystick is pushed forward, the positioner will tilt forward. An arrow will appear pointing forward (▲) on the LCD screen.
- When joystick is pulled back, the positioner will tilt back. An arrow will appear pointing back (▼) on the LCD screen.
- When the joystick is moved to the right, the positioner will rotate to the right. An arrow will appear pointing right (►) on the LCD screen.
- When the joystick is moved to the left, the positioner will rotate to the left. An arrow will appear pointing left (◄) on the LCD screen.
- It is possible to simultaneously adjust both the pan and tilt of the positioner by moving the joystick towards a diagonal. Arrows for both applicable directions will appear on the LCD screen. For example, when tilting forward and panning right, both an arrow pointing forward and an arrow pointing right will appear (▲►).

The positioner will continue to move in the direction given by the joystick until the joystick is released or centered, or the positioner reaches one of its limits. Note that the positioner motor and gearbox assemblies are designed to be stalled when they hit an obstruction, but that continuous abuse will cause damage.

3.3.6 Menu Functions

The controller has been designed to use the joystick as the primary controller for menu function.

To access menu functions:

1. Ensure power is on to the system.
2. Press [Menu] for (2) seconds. The Menu screen (Figure 3-5) will appear.

- 
1. Keyboard setup
 2. Dome setup
 3. Protocol select
 4. Exit menu

Figure 3-5 Menu Screen

3. Use the joystick to navigate through the menu. The number keys can also be used to assist in navigating through the menu.

Detailed steps of specific menu functions are listed in Section 3 and Section 5.

3.3.7 Presets

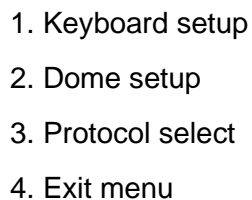
Preset positions can be stored to a preset number between (1) and (50).

The controller comes from the factory with the preset [0] (zero) set to move the positioner to the mid-point of both the pan and tilt. In this position the tilt platform will be horizontal and the pan axis will be in the center position. This is referred to as the Home position.

The customer can program a stowed position by setting preset position [1]. The customer can program an unstow position by setting preset position [2].

Presets can be set or recalled using the keyboard keys, or through menu functions. Presets can only be cleared through menu functions. It is possible to overwrite presets through either method.

3.3.7.1 Setting Presets with the Keyboard

To store a preset position using the keyboard:

1. Use the joystick to drive the positioner to the desired position for the preset.
2. Press [Set].
3. Press [N] where “N” represents the number being assigned to the preset position.
4. Press [Pre]. The preset position is stored.

3.3.7.2 Recalling Presets with the Keyboard

The preferred way to recall a preset position is with the keyboard as moving the joystick while in the menu will not stop the motion of the positioner (e.g. if an emergency stop is required).

To recall a stored preset position using the keyboard:

1. Press [N] where “N” represents the number assigned to the desired preset position.
2. Press [Pre]. The positioner will move to the preset position. When moving to a preset position, the positioner will:
 - First pan and then tilt when moving to the stowed position
 - First tilt and then pan when moving to the unstowed position
 - Simultaneously pan and tilt for any user defined preset position other than stowed or unstowed

As the positioner nears the preset position, it will slow down. If an emergency stop is required as the positioner is moving to a preset position, move the joystick to cancel out the preset position command.

3.3.8 Electronic Limit Stops

The positioner uses electronic limit stops. The positioner does not have mechanical hard stops. The positioner comes from the factory with electronic limit stops set to the maximum recommended pan and tilt. The limit stops can be adjusted through the controller.

The electronic limits are set as follows:

- Pan limit stops are set to 400° of rotation ($\pm 200^\circ$)
- Tilt limit stops are set to 180° of rotation ($\pm 90^\circ$)

The default limits allow the maximum amount of travel possible from the gearboxes. If the tilt limit stops are reset to their default settings, it is possible to drive the payload platform into contact with the chassis connector or positioner body. This will cause damage to the positioner to occur.

3.3.8.1 Adjust Limit Stops with the Keyboard

To adjust the electronic limit stops with the keyboard:

1. Use the joystick to drive the positioner to the desired electronic limit stop.
2. Press [Set].
3. Press [N] where “N” represents the number which corresponds to the preset being adjusted. Reference Table 3-2 to determine which number to use to change each electronic limit stop.

Table 3-2 Limit Stop Adjustment Numbers

Store Preset	Function
80	Stores new counterclockwise limit
81	Stores new clockwise limit
82	Stores new up limit
83	Stores new down limit

4. Press [Pre]. The electronic limit has been adjusted and the positioner will no longer move past that point.

Note that it is possible to set the electronic limit stops such that the positioner cannot move (e.g. setting the clockwise and counterclockwise limits to the same spot). If this happens, restore the electronic limit stops.

3.3.8.2 Restore Limit Stops with the Keyboard

To restore the electronic limit stops to factory settings with the keyboard:

1. Press [Set].
2. Press [N] where “N” represents the number which corresponds to the preset being restored. Reference Table 3-3 to determine which number to use to change each electronic limit stop.

Table 3-3 Default Limit Stop Numbers

Store Preset	Function
70	Restores default counterclockwise limit
71	Restores default clockwise limit
72	Restores default up limit
73	Restores default down limit

3. Press [Pre]. The electronic limit has been adjusted back to the factory default.

3.4 Unstowing the Positioner

The customer must set preset position [2] before this function can be used.

To unstow the positioner:

1. Power on the system.
2. Perform the pre-operation check (Section 3.1).
3. Press [2].
4. Press [Pre]. The positioner will move to the preset unstowed position. When moving to the unstowed position, the positioner will first tilt and then pan. As the positioner nears the unstowed position, it will slow down. If an emergency stop is required as the positioner is moving to position, move the joystick to cancel out the command. The system is unstowed and ready for use.

3.5 Stowing the Positioner

The customer may desire to adjust preset position [1] before using this function.

To stow the positioner:

1. Perform the pre-operation check (Section 3.1).
2. Press [1].
3. Press [Pre]. The positioner will move to the preset stowed position. When moving to the stowed position, the positioner will first pan and then tilt. As the positioner nears the stowed position, it will slow down. If an emergency stop is required as the positioner is moving to position, move the joystick to cancel out the command. The system is stowed.
4. Power down the system.

3.6 Transportation

Before transporting the system, the system needs to be secured. Do not transport without the positioner stowed and secured. It is the responsibility of the customer to properly secure the payload when transporting the system.

Section 4 Maintenance

This section describes maintenance of the system. Be sure to read and understanding the entire maintenance procedure before beginning maintenance.

4.1 Routine Maintenance

Maintain the positioner as follows:

- Visually inspect to ensure the positioner is kept clean.
- Visually inspect for damage. If damage is apparent, do not use the positioner and have it serviced prior to use.
- Inspect to ensure all fixings and fastenings are tight. All fixings and fastenings must be thoroughly checked for tightness (1) month following installation, and thereafter at regular (6) month intervals.
- Inspect to ensure cables are undamaged and properly terminated. Cabling of the correct type as specified by national and local standards should be used. Cables should be checked for wear at (6) month intervals and replaced as necessary.
- Ensure no water can enter the positioner particularly through the connectors. Water can cause extreme problems with the positioner.

4.2 Replacement Parts

To order spare or replacement parts, refer to the part numbers list in Section 1.6.

(This page is intentionally left blank.)

Section 5 Troubleshooting

This section describes troubleshooting of the system. Do not open the positioner. Opening the positioner will break the environmental seal and potentially cause improper stop limit settings. This will void the warranty. This troubleshooting guide assumes:

- Use of (1) positioner, either PI-35, PI-75 or PI-150.
- Use of (1) default joystick controller (P/N: 5098901)

5.1 Troubleshooting Guide

This section covers troubleshooting as follows:

- Positioner (Table 5-1)
- Controller (Table 5-2)

Table 5-1 Troubleshooting the Positioner

Symptoms	Possible Cause	Remedy
Positioner Does Not Pan or Tilt		
Positioner does not pan or tilt in a single direction.	An electronic limit stop has been reached.	Reset the electronic limit stops (Section 3.3.8).
Positioner does not pan or tilt in multiple directions.	The system is not receiving power.	Check the schematics (Section 7).
	The power supply is wrong.	Check the schematics (Section 7).
	System settings are incorrect.	Reset the factory defaults (Section 5.2).
	The controller is in a menu.	Exit the menu.
	The system wiring is incorrect.	Check the schematics (Section 7).
	Wires are broken or improperly terminated.	Check the wires and connections.
	The electronic limit stops have been reset so that the positioner cannot move.	Reset the electronic limit stops (Section 3.3.8).
	The positioner is faulty.	Contact the factory.
Positioner Pans or Tilts Improperly		
Positioner pans or tilts in the wrong direction.	The wiring is incorrect.	Check the schematics (Section 7).
	The positioner is faulty.	Contact the factory.

Table 5-2 Troubleshooting the Controller

Symptoms	Possible Cause	Remedy
Cannot Access the Controller Menu		
The operator cannot access the controller menu.	The controller is not receiving power and the display screen is off.	Power on the system.
		Check the schematics (Section 7).
	The [Menu] button does not respond as quickly as other buttons.	Hold the [Menu] button down for at least (2) seconds.
Stuck in Controller Menu		
While in menu functions, the operator cannot exit a menu.	The method to exit individual menus varies.	Move the joystick to the left to back out of the menu.
		Press the [Prev] button to back out of the menu.
		Look for an <Exit menu> option. Select that option.
		Disconnect and reconnect power to the controller.
The Controller Display is Off		
The controller display is off.	The system is not receiving power.	Check the schematics (Section 7).
	The power supply is wrong.	Check the schematics (Section 7).
	The system wiring is incorrect.	Check the schematics (Section 7).
	The controller is faulty.	Contact the factory.

5.2 Restoring Factory Defaults

The system is designed to function using the factory defaults shown in Figure 5-1. These settings will display when the controller is powered on. If these defaults are changed, the system may not function properly. There is no single key or command sequence to reset all factory settings.

CamID: 001	MonID: 001
Protocol:	Pelco-d
Baudrate:	2400

Figure 5-1 Start Up Screen

To reset these settings proceed as follows:

5.2.1 CamID

When the controller is powered on, the CamID will be displayed. The CamID should be 001. If necessary, reset the CamID to 001. To reset the CamID:

1. From the start up screen (Figure 5-1), press [1].
2. Press [Cam]. The CamID will change to 001. The setting is saved.

5.2.2 MonID

When the controller is powered on, the MonID will be displayed. The MonID should be 001. If necessary, reset the MonID to 001. To reset the MonID:

1. From the start up screen (Figure 5-1), press [1].
2. Press [Mon]. The MonID will change to 001. The setting is saved.

5.2.3 Protocol

When the controller is powered on, the protocol will be displayed. The protocol should be Pelco D. If necessary, reset the protocol to Pelco D. A quick guide to resetting the protocol can be found in Table 5-3.

Table 5-3 Resetting the Protocol

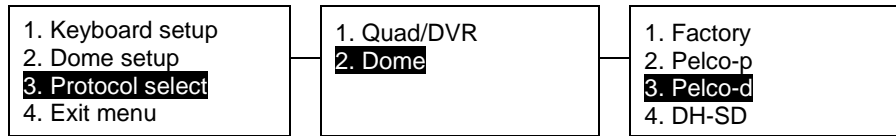

To reset the protocol:

1. Press [Menu] for (2) seconds. The Menu screen will appear (Figure 5-2).

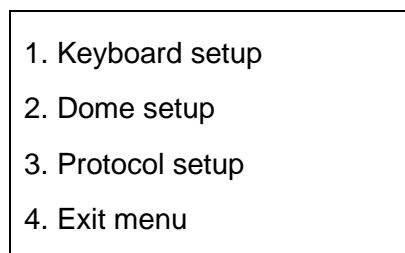

Figure 5-2 Menu Screen

2. Navigate to <Protocol setup> and move the joystick to the right to go to the submenu. The Protocol setup screen will appear (Figure 5-3).

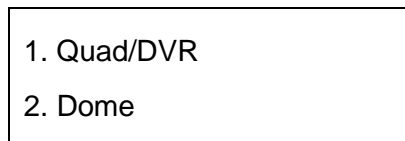

Figure 5-3 Protocol Setup Screen

3. Navigate to <Dome> and move the joystick to the right to go to the submenu. The Dome screen will appear (Figure 5-4).

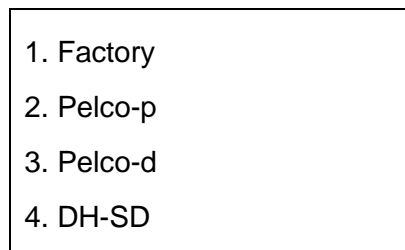

Figure 5-4 Dome Screen

4. Navigate to <Pelco-d> and move the joystick to the right to select Pelco D as the protocol. <Success!> will briefly flash at the bottom of the LCD screen and the display will return to the Protocol setup screen (Figure 5-3). The setting is saved.

5.2.4 Baud Rate

When the controller is powered on, the baud rate will be displayed. The baud rate should be 2400 bps. If necessary, reset the baud rate to 2400. A quick guide to resetting the baud rate can be found in Table 5-4.

Table 5-4 Resetting the Baud Rate

<ol style="list-style-type: none"> 1. Keyboard setup 2. Dome setup 3. Protocol select 4. Exit menu 	<ol style="list-style-type: none"> 1. Set KB ID(1-64): 2. Set baudrate: 2400 3. Joy-calibrate 4. About Keyboard 	<ol style="list-style-type: none"> 1. Set KB ID(1-64): 2. Set baudrate: 2400 3. Joy-calibrate 4. About Keyboard 	<p>Move the joystick down until the number beside <Set baudrate> reads 2400, then move the joystick right.</p>
--	---	---	--

To reset the baud rate:

1. Press [Menu] for (2) seconds. The Menu screen will appear (Figure 5-2).
2. While remaining on <Keyboard setup>, move the joystick to the right to go to the submenu. The Keyboard setup screen (Figure 5-5) will appear. The number beside <2. Set baudrate:> may vary.

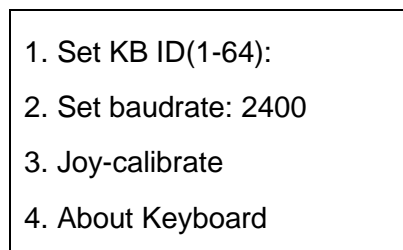

Figure 5-5 Keyboard Setup Screen

3. Navigate to <Set baudrate> and move the joystick to the right. The screen will remain the same, but the number beside <2. Set baudrate:> will be selected.
4. Move the joystick forward or backward to adjust the baud rate.
5. Move the joystick to the right to save the baud rate. <Success!> will briefly flash at the bottom of the LCD screen and the display will return to the Menu screen (Figure 5-2). The setting is saved.

(This page is intentionally left blank.)

Section 6 Appendix

This section contains the appendix for your system.

Follow all precautions when installing and operating components discussed in this section. Contact the Will-Burt Company with any questions before performing any procedure outlined in this manual.

6.1 Rackmount Controller (optional)

In applications where an in-built controller is required Will Burt can offer a controller which can work with Will-Burt positioners. Please contact Will Burt sales team for further information.



6.2 Supported Pelco D Commands

STANDARD COMMANDS	Op Code*	Hex Code	Decimal Code
STOP (Stop all Movement)	00	FF 01 00 00 00 00 01	255 001 000 000 000 000 001
Pan Right (Max. Speed)	02	FF 01 00 02 3F 00 42	255 001 000 002 063 000 066
Pan Left (Max. Speed)	04	FF 01 00 04 3F 00 44	255 001 000 004 063 000 068
Tilt Up (Max. Speed)	08	FF 01 00 08 00 3F 48	255 001 000 008 000 063 072
Tilt Down (Max. Speed)	10	FF 01 00 10 00 3F 50	255 001 000 016 000 063 080
Pan Right & Tilt Up (Max. Speed)	0A	FF 01 00 0A 3F 3F 89	255 001 000 010 063 063 137
Pan Right & Tilt Down (Max. Speed)	0C	FF 01 00 0C 3F 3F 8B	255 001 000 012 063 063 139
Pan Left & Tilt Up (Max. Speed)	12	FF 01 00 12 3F 3F 91	255 001 000 018 063 063 145
Pan Left & Tilt Down (Max. Speed)	14	FF 01 00 14 3F 3F 93	255 001 000 020 063 063 147
EXTENDED COMMANDS	Op Code*	Hex Code	Decimal Code
Set Preset	03	FF 01 00 03 00 nn xx	255 001 000 003 000 nnn xxx
Clear Preset	05	FF 01 00 05 00 nn xx	255 001 000 005 000 nnn xxx
Go To Preset	07	FF 01 00 07 00 nn xx	255 001 000 007 000 nnn xxx
ADVANCED COMMANDS	Op Code*	Hex Code	Decimal Code
Set Pan Position (Absolute Position – Pan)	4B	FF 01 00 4B mm ll xx	255 001 000 075 mmm lll xxx
Set Tilt Position (Absolute Position – Tilt)	4D	FF 01 00 4D mm ll xx	255 001 000 077 mmm lll xxx
Query Pan Position	51	FF 01 00 51 00 00 52	255 001 000 081 000 000 082
Query Pan Position Response	59	FF 01 00 59 mm ll xx	255 001 000 089 mmm lll xxx
Query Tilt Position	53	FF 01 00 53 00 00 54	255 001 000 083 000 000 084
Query Tilt Position Response	5B	FF 01 00 5B mm ll xx	255 001 000 091 mmm lll xxx
CUSTOM COMMANDS	Op Code*	Hex Code	Decimal Code
*Not Currently Supported by Accupoint Positioners			
Query Movement Status	C1	FF 01 00 C1 00 00 C2	255 001 000 193 000 000 194
Query Movement Status Response [Go To Preset Active]	C3	FF 01 00 C3 00 10 D4	255 001 000 195 000 016 212
Query Movement Status Response [No Movement Sensed]	C3	FF 01 00 C3 00 00 C4	255 001 000 195 000 000 196
Query Movement Status Response [Up Limit Reached]	C3	FF 01 00 C3 00 01 C5	255 001 000 195 000 001 197
Query Movement Status Response [Down Limit Reached]	C3	FF 01 00 C3 00 02 C6	255 001 000 195 000 002 198
Query Movement Status Response [Left Limit Reached]	C3	FF 01 00 C3 00 08 CC	255 001 000 195 000 008 204
Query Movement Status Response [Right Limit Reached]	C3	FF 01 00 C3 00 04 C8	255 001 000 195 000 004 200
Query Movement Status Response [Up & Right Limit Reached]	C3	FF 01 00 C3 00 05 C9	255 001 000 195 000 005 201
Query Movement Status Response [Up & Left Limit Reached]	C3	FF 01 00 C3 00 09 CD	255 001 000 195 000 009 205
Query Movement Status Response [Down & Right Limit Reached]	C3	FF 01 00 C3 00 06 CA	255 001 000 195 000 006 202
Query Movement Status Response [Down & Left Limit Reached]	C3	FF 01 00 C3 00 0A CE	255 001 000 195 000 010 206
CUSTOM PRESETS (USER DEFINED LIMITS ... Set Preset Op)	Op Code*	Hex Code	Decimal Code
Preset 70 Restore Default Left Limit	03	FF 01 00 03 00 46 4A	255 001 000 003 000 070 074
Preset 71 Restore Default Right Limit	03	FF 01 00 03 00 47 4B	255 001 000 003 000 071 075
Preset 72 Restore Default Up Limit	03	FF 01 00 03 00 48 4C	255 001 000 003 000 072 076
Preset 73 Restore Default Down Limit	03	FF 01 00 03 00 49 4D	255 001 000 003 000 073 077
Preset 80 Store New Left Limit	03	FF 01 00 03 00 50 54	255 001 000 003 000 080 084
Preset 81 Store New Right Limit	03	FF 01 00 03 00 51 55	255 001 000 003 000 081 085
Preset 82 Store New Up Limit	03	FF 01 00 03 00 52 56	255 001 000 003 000 082 086
Preset 83 Store New Down Limit	03	FF 01 00 03 00 53 57	255 001 000 003 000 083 087

Section 7 Drawings

This section contains drawings of the system.

REVISIONS						
ECN	REV	DESCRIPTION	DATE	BY	CK	OK
12656	00	INITIAL RELEASE	4/3/2015	JLK	DJB	AW
12831	A	INITIAL PRODUCTION CHANGES	7/29/2015	JLK	DJB	AW
13128	B	CHNGD CON. BACKSHELL; UPDATE TABLES	2/24/2016	JLK	DJB	AW

12 VDC APPLICATION

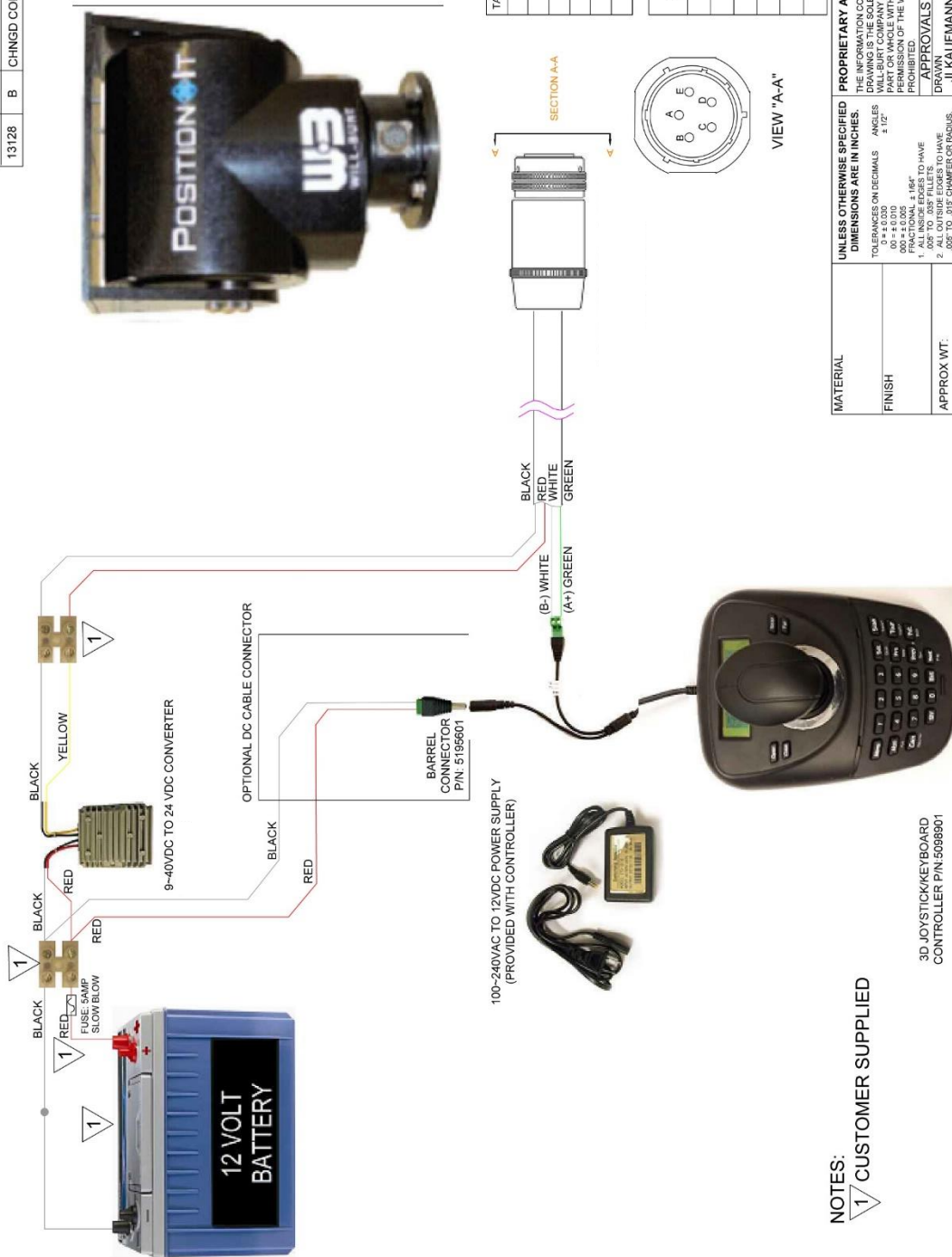

TABLE 1: POWER & DATA PIN OUT

PIN	FUNCTION	WIRE
A	DATA "A"	GREEN
B	DATA "B"	WHITE
C	+ 24VDC	RED
D	- 24VDC	BLACK
E	GROUND	SHIELD

TABLE 2: CABLE ASSEMBLY PART NUMBERS PER LENGTH

P/N	LENGTH
5195401	150 FT (45.72m)
5195402	100 FT (30.48m)
5195403	75 FT (22.86m)
5195404	50 FT (15.24m)
5195405	25 FT (7.62m)

NOTES:
 1 CUSTOMER SUPPLIED

3D JOYSTICK/KEYBOARD CONTROLLER P/N:5095901

UNLESS OTHERWISE SPECIFIED DIMENSIONS ARE IN INCHES.
 TOLERANCES ON DECIMALS: ANGLES ± 1/2°
 0.000 ± 0.030
 0.001 ± 0.005
 0.002 ± 0.005
 0.004 ± 0.005
 1. FRACTIONAL DIMENSIONS TO HAVE 1/16" MINIMUM INCREMENT
 2. .005" TO .035" FILLETS
 3. .005" TO .035" CHAMFER OR RADIUS
 1/2" √ DW ALL MACHINED SURFACES

PROPRIETARY AND CONFIDENTIAL
 THE INFORMATION CONTAINED IN THIS DRAWING IS THE SOLE PROPERTY OF THE WILL-BURT COMPANY. NO PART OR WHOLE WITHOUT THE WRITTEN PERMISSION OF THE WILL-BURT COMPANY IS PROHIBITED.

APPROVALS
 DRAWN BY: J. KAUFMANN
 DATE: 4/3/2015
 CHECKED:

WIRING DIAGRAM
 DWG NO: WD-50610
 P/N:

WILL-BURT AN EMPLOYEE OWNED COMPANY
 WILL-BURT ORRVILLE, OH

PositionIT

SHEET 1 OF 4

REVISIONS						
ECN	REV	DESCRIPTION	DATE	BY	CK	OK
12656	00	INITIAL RELEASE	4/3/2015	JLK	DJB	AW
12831	A	INITIAL PRODUCTION CHANGES	7/29/2015	JLK	DJB	AW
13128	B	CHNGD CON. BACKSHELL; UPDATE TABLES	2/24/2016	JLK	DJB	AW

120/240 VAC APPLICATION

AC LINE (BROWN)
AC NEUTRAL (BLUE)
EARTH GROUND (GREEN/YELLOW)

1 CUSTOMER SUPPLIED PLUG

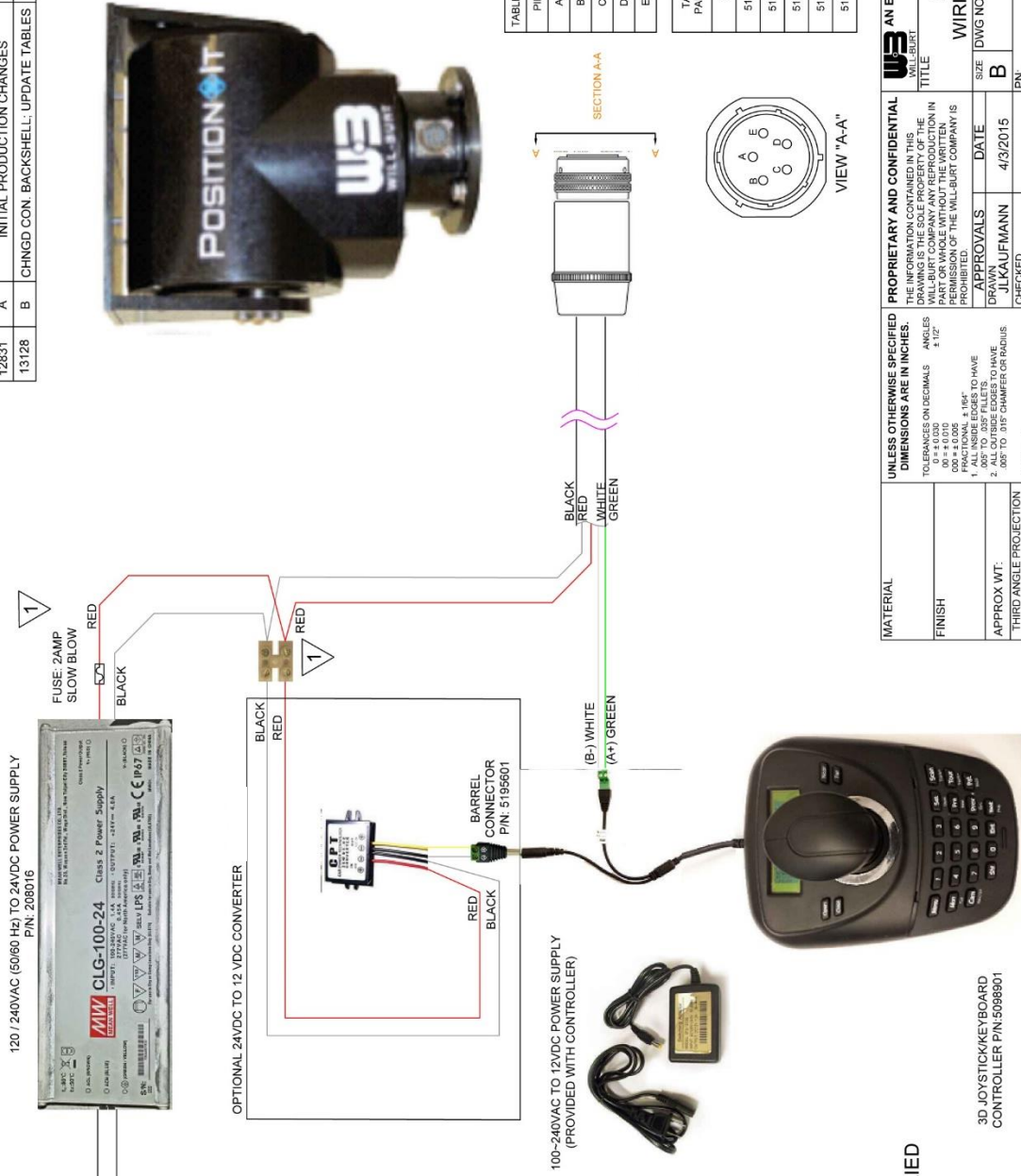
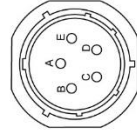

TABLE 1: POWER & DATA PIN OUT

PIN	FUNCTION	WIRE
A	DATA "A"	GREEN
B	DATA "B"	WHITE
C	+24VDC	RED
D	-24VDC	BLACK
E	GROUND	SHIELD

TABLE 2: CABLE ASSEMBLY PART NUMBERS PER LENGTH

PIN	LENGTH
5195401	150 FT (45.72m)
5195402	100 FT (30.48m)
5195403	75 FT (22.86m)
5195404	50 FT (15.24m)
5195405	25 FT (7.62m)



NOTES:
1/ CUSTOMER SUPPLIED

WILL-BURT AN EMPLOYEE OWNED COMPANY
ORRVILLE, OH

PositionIT
WIRING DIAGRAM

DRW NO: **WD-50610** REV: **B**

DATE: **4/3/2015** CHECKED: **JLK/DFMANN**

APPROX WT.: **125** THIRD ANGLE PROJECTION

UNLESS OTHERWISE SPECIFIED DIMENSIONS ARE IN INCHES. TOLERANCES ON DECIMALS: 0 ± 0.000, 0.001 ± 0.005, 0.002 ± 0.005, 0.005 ± 0.005, 0.007 TO .355 FILLETS, 0.002 TO .315 CHAMFER OR RADIUS. ANGLES: ± 12'. FRACTIONAL SIZES TO HAVE .002 TO .355 FILLETS. 2.002 TO .315 CHAMFER OR RADIUS.

PROPRIETARY AND CONFIDENTIAL THE INFORMATION CONTAINED IN THIS DRAWING IS THE SOLE PROPERTY OF THE WILL-BURT COMPANY. NO PART OR WHOLE WITHOUT THE WRITTEN PERMISSION OF THE WILL-BURT COMPANY IS PROHIBITED.

MATERIAL: **FINISH**

3D JOYSTICK/KEYBOARD CONTROLLER P/N: 5098901